

BRVELIFTCALLLINE

Lift Communicator BLCL

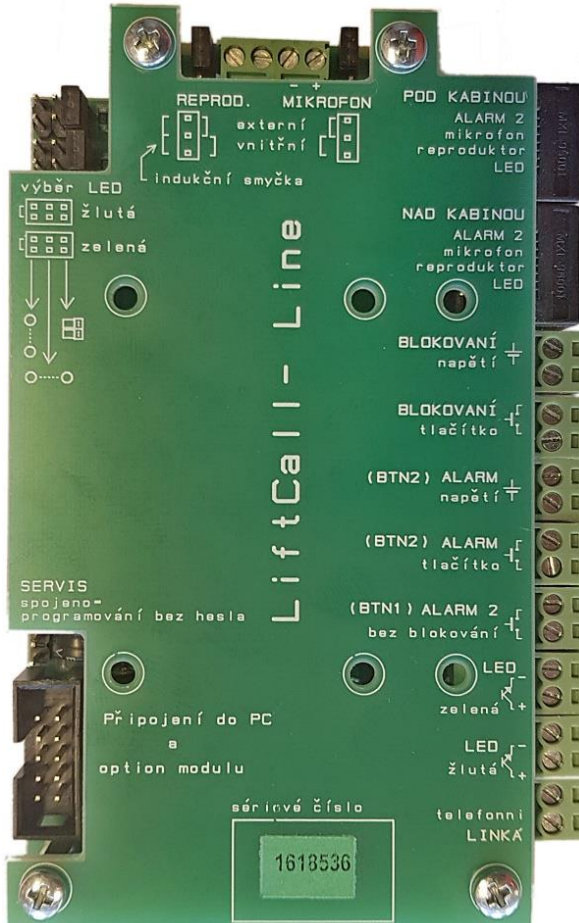

USER GUIDE

Welcome

The BraveLiftCallLine Lift Communicator is designed for emergency call from lift to first aid (service department, police, etc...)

The BraveLiftCallLine is certified for 1 lift cabin. It is connectable to analog PSTN line or analog extension of PABX. The BraveLiftCallLine is powered from telephone line – the features reminds hands free phone. Is possible to one telephone line connect up to 5 BraveLiftCallLine communicators parallel. It is completely independent on lift power supply. The LED signalization as same as status detection is powered from telephone line, extended signalization requires only connect the LEDs without external power supply. Inputs on basic module are galvanically connected with telephone line, only inputs marked by the symbol battery is galvanically isolated and activate is possible by connect external voltage.

Basic module is possible expand on Option module. The Option module is powered only from 12/24V and it's galvanically isolated from telephone line including inputs and outputs on the Option board.

The BraveLiftCallLine has adjustable parameters saved in internal memory. The parameters might be programmed either by phone via tone (DTMF) dial or by computer PC via configuration software. For connection the BraveLiftCallLine to PC you have to use special USB cable.

After button pressing the BraveLiftCallLine enables to make phone call up 6 numbers max 16 digits in tone or pulse dial. It is possible also dial “ * ”, “ # ”, **Pause** and **Flash** in tone dial. The button activation might be blocked by input FILTER.

At all numbers is possible to use mode with or without confirmation.



The manufacturer continuously improves the product firmware. The technology used allows you to upload to BraveLiftCallLine the latest version of the firmware any time using a standard computer with BraveLiftCallLineSet and USB cable. The latest version of the firmware is available at <http://www.alphatechtechnologies.cz>

Manual version V4.9 16.8.2018

(for FW 4.9 and higher)

ALPHATECH TECHNOLOGIES s.r.o.

Jeremenkova 88

140 00 Praha 4 - CZ

tel: (+420) 244 467 562

<http://www.alphatechtechnologies.cz>

sales@alphatechtechnologies.cz



ALPHA
Tech

Content

1.	BASIC DESCRIPTION.....	6
1.1	FEATURES	6
1.2	TERMINOLOGY	7
1.3	DESCRIPTION OF THE MODULES	8
1.3.1	<i>Description of basic module</i>	<i>8</i>
1.3.2	<i>Explanation of all mount points</i>	<i>10</i>
1.4	CONNECTION BASIC MODULE	12
1.4.1	<i>Connection telephone line.....</i>	<i>12</i>
1.4.2	<i>Connection emergency push button</i>	<i>13</i>
1.4.3	<i>Connection external indication.....</i>	<i>15</i>
1.4.4	<i>Connection filtering call from ALARM.....</i>	<i>16</i>
1.4.5	<i>Jumpers description</i>	<i>17</i>
1.5	CONNECTION OVER - UNDER CABIN	18
1.6	CONNECTION SWITCHBOARD	19
1.6.1	<i>Wiring SwitchBoard.....</i>	<i>19</i>
1.6.2	<i>Functions SwitchBoard.....</i>	<i>19</i>
1.6.3	<i>Programming SwitchBoard</i>	<i>21</i>
1.7	CONNECTION TALKER MODULE	22
1.8	INSTALLATION	24
1.9	ACOUSTIC PATH SETTING	25
2.	LIFTCALLLINE SERVICE.....	26
2.1	SIGNALLING OVERVIEW	26
2.2	CALLING FROM BRAVELIFTCALLLINE.....	27
2.2.1	<i>Emergency call (button activation).....</i>	<i>27</i>
2.2.2	<i>Emergency call with cancelation (Alarm button)</i>	<i>28</i>
2.2.3	<i>Service calling (from timer).....</i>	<i>28</i>
2.2.4	<i>End of calling – call confirmation</i>	<i>29</i>
2.2.5	<i>Machine room connection.....</i>	<i>30</i>
2.2.6	<i>Incoming call</i>	<i>30</i>
2.2.7	<i>Parallel connection BraveLiftCallLine communicators.....</i>	<i>31</i>
2.2.8	<i>CallCentrum and types of calls.....</i>	<i>33</i>
2.2.9	<i>End of Alarm.....</i>	<i>33</i>
3.	PARAMETERS PROGRAMMING	34
3.1	PROGRAMMING BY TELEPHONE:.....	34
3.1.1	<i>Enter to programming mode.....</i>	<i>34</i>
3.1.2	<i>Programming of parametres.....</i>	<i>34</i>
3.2	PC PROGRAMMING– PROGRAMM BLCL-KONFIGURATOR	35
3.2.1	<i>Install program BLCL-konfigurator</i>	<i>36</i>
3.3	REMOTE PROGRAMMING FROM PC.....	37
3.3.1	<i>Procedure remote connection</i>	<i>37</i>
3.3.2	<i>Read settings remotely.....</i>	<i>38</i>
3.3.1	<i>Compare reading value.....</i>	<i>38</i>
3.3.2	<i>Write settings remotely</i>	<i>39</i>

- 4. PARAMETERS DESCRIPTION 40**
 - 4.1 PHONE NUMBERS MEMORY 40
 - 4.2 LIFT OPERATION 42
 - 4.3 BASIC PARAMETRES 44
 - 4.4 TIME PARAMETRES 47
 - 4.5 SYSTEM PARAMETERS 51
 - 4.6 HANDSFREE PARAMETRES SETTING 54
 - 4.7 OPTION MODULE PARAMETERS 57
 - 4.8 PRESETTING AND ERASING 59
 - 4.9 ENDING OF PROGRAMMING 60
 - 4.10 PARAMETERS OVERVIEW 61
- 5. TECHNICAL PARAMETRES 64**
 - 5.1 ELECTRICAL PARAMETRES 64

1. Basic description

1.1 Features

- The Basic unit is powered from telephone line only.
- The unit includes acoustic part (microphone and speaker) and LED indication – compact solution!
- Programming is either remotely by phone (DTMF tones) or by PC (cable on USB port).
- It includes indication light (LED) – yellow, indication of dialling the number.
- It includes indication light (LED) – green, indication confirm of call.
- Possible connect pushbutton with switch-on or switch-off contacts
- Possible connect two pushbuttons - one (Alarm) with blocking second (Alarm2) without function blocking (FILTER)
- Input FILTER for blocking dial from button ALARM
- Special mode with autoblocking function (from move of cabine door)
- The time of each button activation is adjustable from 0,5 sec to 39 sec
- Inputs on Basic unit is galvanic connect with telephone line, inputs with symbol battery is isolated and activate is possible only by external voltage
- The possibility up to 3 communicators parallel from „SwitchBoard“ for communication with machine room
- Automatic control of system functionality - Service call (automatic calling to preprogrammed numbers in set time period from 1 to 10 days)
- Possible switched on acoustic tick to the conversation for speech recognition
- Adjustable parameters of tone dial, length of Flash and Pause
- Adjustable parameters of tones detector and parameters of acoustical signalization
- Elektronical loudness settings (without necessity open the unit)
- The possibility to program 6 numbers (16 digits – includes *,#,Pause,Flash) with note if you want use confirmation or not .The numbers are progressively dial.
- Automatic test of acoustic path (microphone and speaker). Switchtable by parameter.
- Automatic test of permanent activate buttons (ALARM2 or BTN2)
- Possibility call to the machine room with SwitchBoard
- Possibility set mute for service, technical and counter calls

1.2 Terminology

It is explain here the meaning of used words in manual.

LiftCallLine	it is final product designed for communication from lift cabin to service center.
Emergency call	it is person calling while lift failure or other emergency situation happened. It is activates by button pushing. The call is being between lift cabin and service center.
Service call	it is calling regularly repeated. (for example every 3 days). It is automatic proving of BraveLiftCallLine communicator functionality.
Technical call	it is three sort and calling caused: <ul style="list-style-type: none">- by long press button Alarm2 like as information "End of Emergency call" (end of alarm)- by status change on input INP1 - INP8 on Option module- by information of not moving cabin (INP/OUT3 on Option module)
Machine room call	it is calling between lift cabin and machine room.
Incoming call	it is calling coming from outside into BraveLiftCallLine unit. The BraveLiftCallLine pick up (you can programm parametres)
Dial	it is kind of dial on telephone line – dial (DTMF) dial (dial even acknowledgement * and # , use loop interruption = Flash) or pulse – (dial only numeral)
Telephone line	PSTN line (public line) (line coming directly from Telecommunication carrier) or extension line (coming from PBX)
Confirmation	dial of combination star * and numerals. After dialling of those characters the call is authorised and lift communicator reply ones of 4 kind answer
Serial number	each lift communicator BraveLiftCallLine has unique serial number since 00001 to 65535. This number is sending via DTMF every time when BraveLiftCallLine receives confirmation character
Call connection	this status is indicated via lighting of green check – light and might be caused either by call confirmation (dial confirmation character) or when is not present ringing tone for longer time period.

1.3 Description of the modules

1.3.1 Description of basic module

The BraveLiftCallLine is compact solution of communicator, it means that contains LED, microphone, connector for PC connection (configuration). At picture 1 and 2 is drawing of BraveLiftCallLine basic board. Functionality of connection is explain in follow chapters.

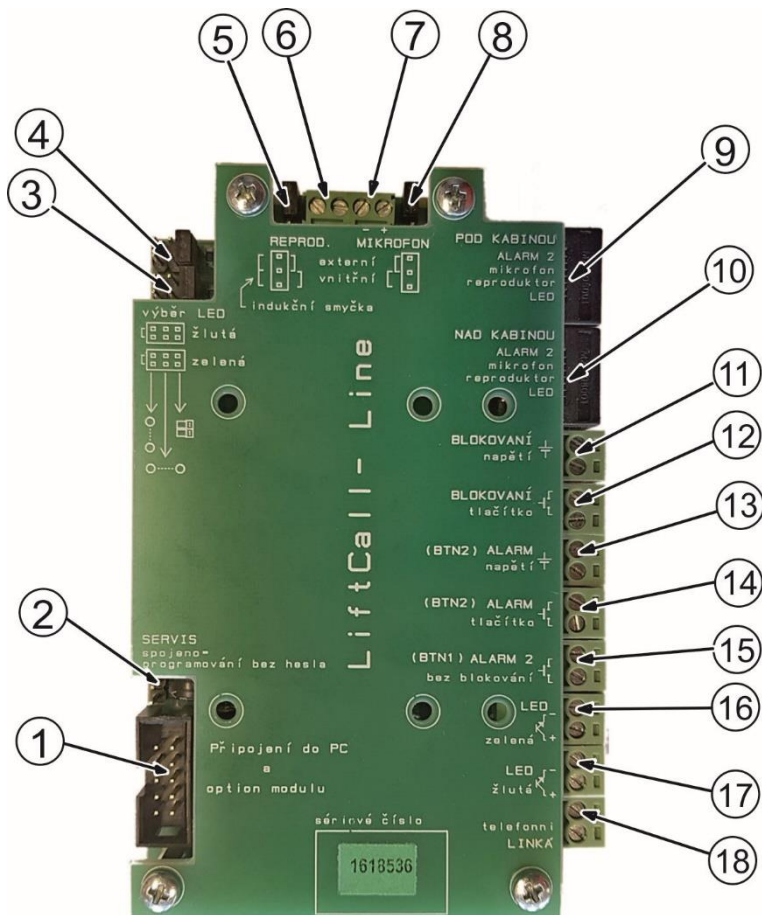

Picture 1: BraveLiftCallLine Basic Board top

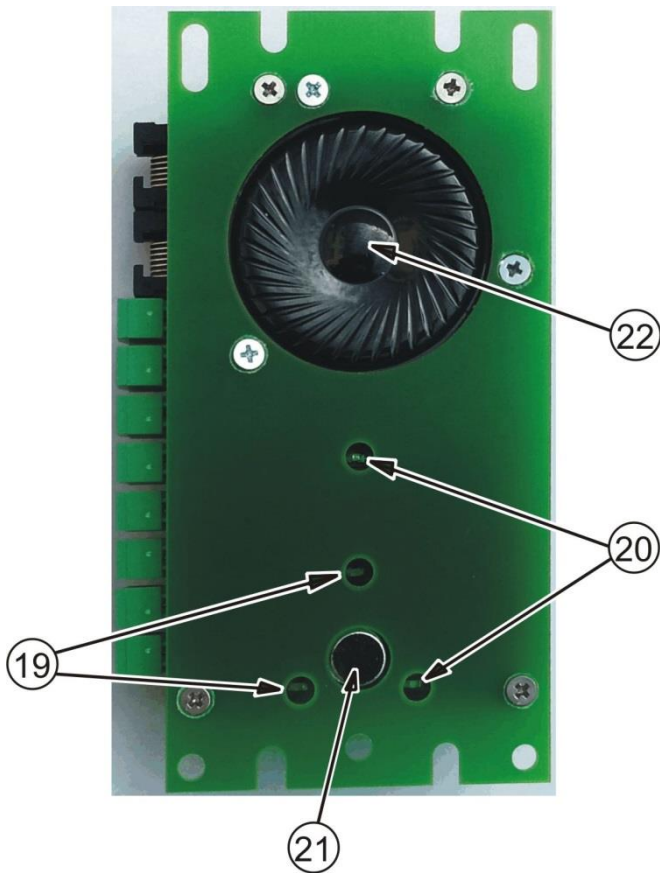

Picture 2 BraveLiftCallLine Basic Board bottom

On Basic board is standard include microphone, speaker and two LED pair of indication. Next possibilities of connection microphone and speaker is two connectors on Basic board or to the connector on Speaker module or the connection two connectors for long distance on over or under cabine. In this connectors (RJ45) is possibility connect LEDs and push button Alarm2. Caution on polarity of microphone because is powered (+ -).

Here you can see that when is set high volume of microphone as same as speaker then signals influence each other. The result might be that call is interrupted or one direction is silent. Volume of all acoustic parameters is settings by program parameters.

1.3.2 Explanation of all mount points

Numbers on picture in circle:

1. connector for **Option module** connection or **PC** connection by special USB cable KAB. The cable is galvanically isolated convertor USB and BraveLiftCallLine interface. Galvanical isolation is necessary because PC might be grounded and telephone line **MUST NOT** be grounded! All signals is galvanically connected with telephone line.
2. the jumper marked **SERVICE** is available for automatic enter to programming mode when password is forgotten. When jumper is ON and you make incoming call on BraveLiftCallLine then after picking up you are directly in programming mode. In programming mode you can change all parametres includes new password as well.
3. **jumpers** for setting output of indication **green LED**, left position is up LEDs column on basic board, middle position is down LEDs row on basic board and down position is LED on green connectors - External indication
4. **jumpers** for setting output of indication **yellow LED**, left position is up LEDs column on basic board, middle position is down LEDs row on basic board and down position is LED on green connectors - External indication
5. jumper **switch internal / external** speaker
6. output for **external speaker** (8-16ohm), if use this output for **inductive loop**, it is need connect all 3 pin of jumper (then is active internal speaker and output for inductive loop together)
7. input for external microphone - attention on polarity of microphone!
8. jumper **switch internal / external** microphone
9. RJ45 connector for speaker, microphone, LEDs and Alarm2 button under cabin
10. RJ45 connector for speaker, microphone, LEDs and Alarm2 button over cabin
11. input **FILTER** for signal **block** of dial from button ALARM, this input is galvanically **isolated** from telephone line. For activate use voltage 5 - 24V, independent of polarity
12. input **FILTER** for signal **block** of dial from button ALARM, this input is gavanically **connect** with telephone line. Use only contact without voltage potential, can be used NO or NC contacts
13. input for button **ALARM** for emergency call with possibilities of filterinkg. This input is gavanically **isolated** from telephone line. For activate use voltage 5 - 24V, independent of polarity
14. input for button **ALARM** for emergency call with possibilities of filterinkg. This input is gavanically **connect** with telephone line. Use only contact Use only contact without voltage potential, can be used NO or NC contacts
15. input for button **ALARM2** for emergency call withtout possibilities of filterinkg. For Technical call - End of Alarm is possible use this button ALARM2, resolution is in time (param. 52) if you hold the button longer then 8 x param.52 this call is Technical call. Use only contact without voltage potential, can be used NO or NC contacts

16. **Green** external indication output - galvanic **connect** with telephone line, output for LED (1mA)
17. **Yellow** external indication output - galvanic **connect** with telephone line, output for LED (1mA)
18. telephone line connection - **LINE**
19. **yellow** LEDs
20. **green** LEDs
21. **microphone**
22. **speaker**

1.4 Connection Basic module

1.4.1 Connection telephone line

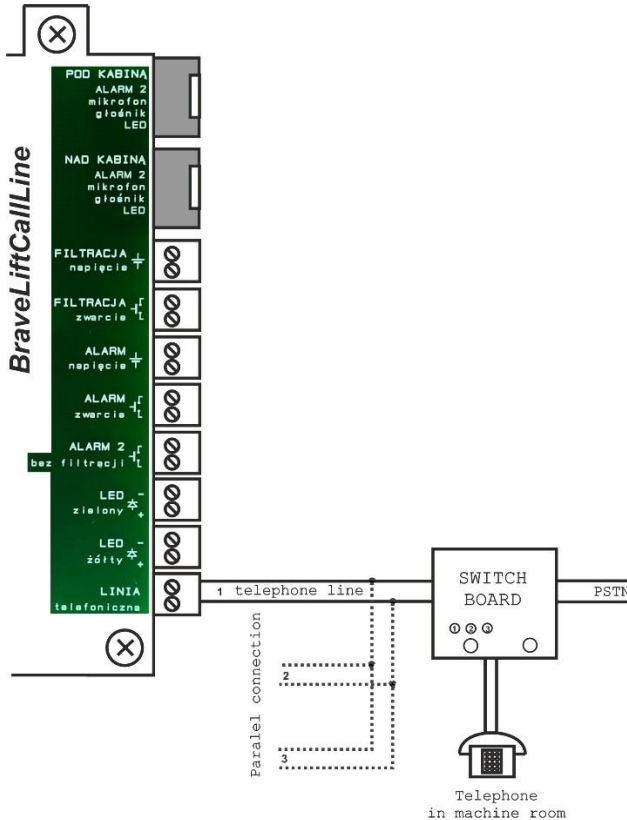

Connector for connection telephone line has two wires for telephone line connection or Switch board connection. If you use Switch board, so it possible parallel connect max. three BraveLiftCallLine and it is necessary to set the parallel mode on communicators and the number of communicators, so that the main is always 1.

Telephone line interface has following typical parametres. The voltage in Hang up status (disconnect loop) 20-60V DC (during connection not depends on polarity), when BraveLiftCallLine pick up (active status) on telephone line is cca 7-12V, depends on line current which is in range 20-60mA. Further telephone line parametres are signalling, ringing (incoming call) is define by AC voltage from 50-90V and frequency 20 – 60Hz. To the signalling belongs even tones, have frequency 425Hz +/- 20Hz and level -10dBm (cca 0,22V) and different cadences. The BraveLiftCallLine reacts on those tones.

1.4.2 Connection emergency push button

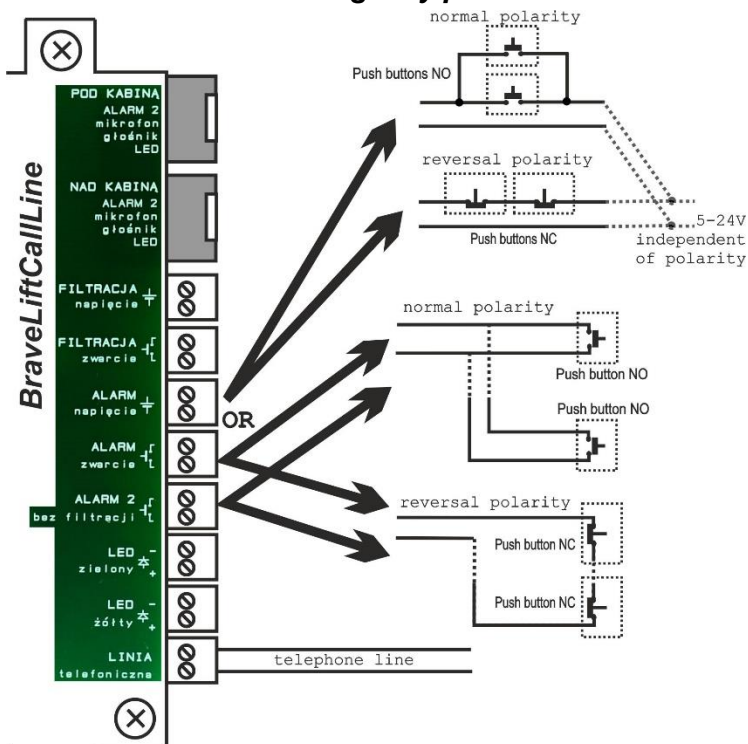

When telephone line is connected we need connect button only.

The button is connected to screw terminal mark ALARM / ALARM2

Button is possible connecting up to 10m and is possible connecting more buttons „switch NO“ parallel or „switch NC“ buttons serial. Control of type buttons use is possible programming by parameter 33 for ALARM and parameter 39 for ALARM2 - 1 or 0

LiftCallLine has two inputs for button connection, ALARM2 is without function filtering telephone dialing and ALARM is with function filtering telephone dialing.

ALARM2 has function Technical call - "End of Alarm", this function is provide long press this button. If you set time for hold button ALARM2 to 2 sec, then if you press ALARM2 shortly time then 2 sec, so BraveLiftCallLine not dial. If you press longer then 2sec, so BraveLiftCallLine dial "Emergency call" and if you press ALARM2 longer then 16 sec (8 x 2sec), so BraveLiftCallLine dial "Technical call". Resolution is 8 times set time in parameter 52.

Use **only** contact without voltage potential and **galvanic isolate** from ground. For button ALARM is possible use for activate by external voltage 5-24V - connector with symbol battery (isolate by optocoupler).

ALARM2 button has three function:

1. emergency call – press ALARM2 longer than time parameter 52 (2sec)
2. technical call – press ALARM2 longer than (time param. 52) x 8 (16sec)
3. cal to the machine room – three times press button ALARM2 (explain in picture)

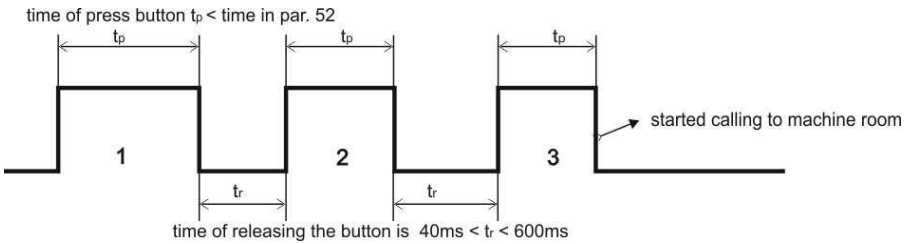

1.4.3 Connection external indication

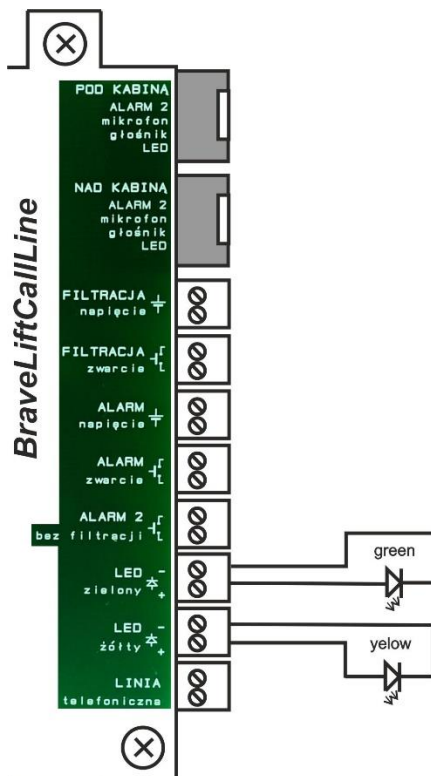

The BraveLiftCallLine is equipped by call status indication. It is by yellow and green status indicator. Standard indication is on Basic board. Next possibilities is connection external. The switcher outputs for those indicators are galvanically connected with telephone line - no connect to any circuit and voltage.

1.4.4 Connection filtering call from ALARM

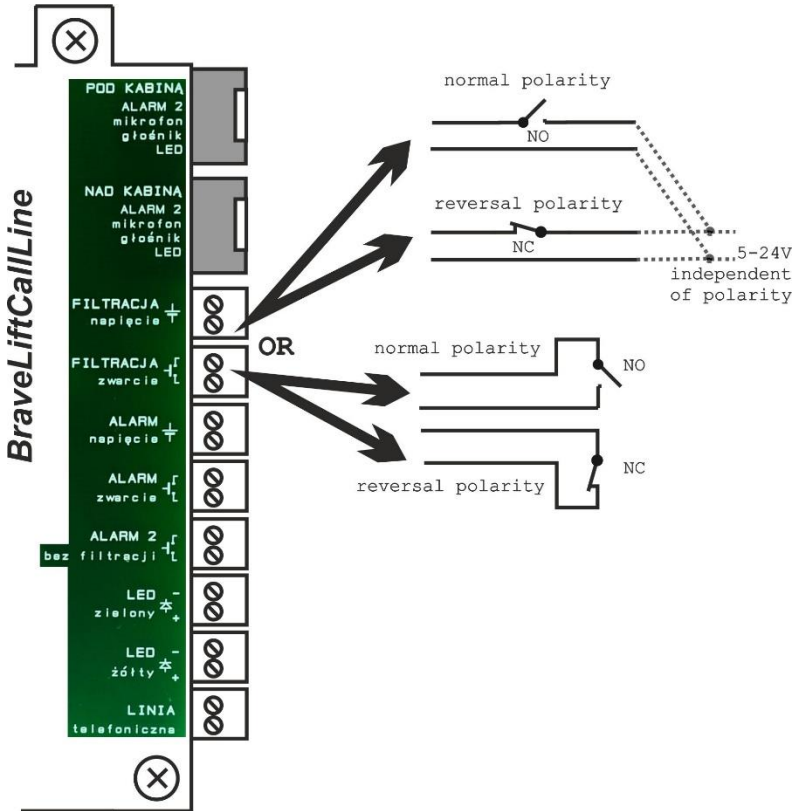

The connector FILTER is designed for filtering of button ALARM for emergency call. Input is galvanically connect with telephone line. Possibility connect contact NO or NC (programable by parameter). Use only contact without voltage potential.

For FILTER is possible use for activate by external voltage 5-24V - connector with symbol battery (isolate by optocoupler).

From Version of Firmware V4.6 is new feature of this input. If we set parameter 34 = 4, so system of Blocking call from Alarm button is disable and this input has new function: present engineer at lift cabin. If engineer arrived on the cabin, switch NO switcher to close and after 1-2min is begin technical call with mark [**]. Before engineer leave the lift cabin switch NO switcher to open and after 1-2min is begin technical call with mark [#*]. If value of parameter 34 is 2 or 3, so BLK has same function of blocking (filtering) call from Alarm input and next call technical call same as in value parameter 34 = 4.

1.4.5 Jumpers description

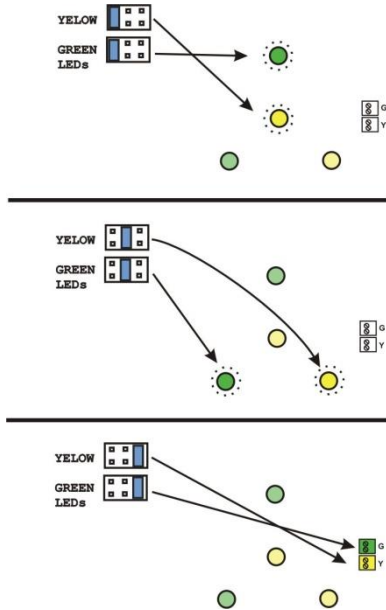

On picture is explain principle of select LEDs indication.

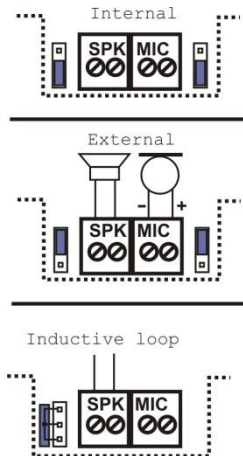

On picture is explain principle of select microphone and speaker on Basic board. If is connected all three pins on SPK, so it is possible use output for inductive loop with fully functionality internal speaker.

1.5 Connection over - under cabin

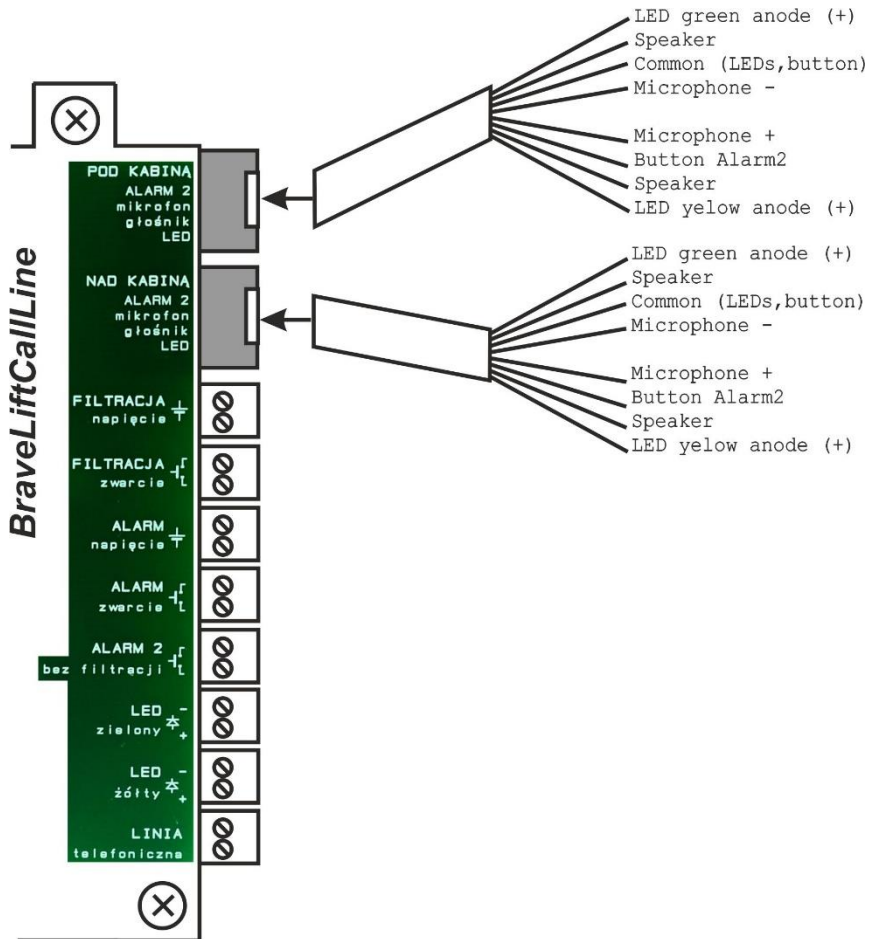

Over - under cabine is possible connect microphone, speaker, button ALARM2 and LEDs (green + yellow). Connection is possible via not crossing cable (8 wires) with crimple connectores RJ45 like as UTP cable with same rule as for ethernet connection.

In this case is available button **ALARM2** for emergency call without possibilities of filterinkg. Use only contact without voltage potential, can be used NO or NC contacts (programable).

For connection over - under cabin is possible connect speaker with impedance higher then 40 ohms (45ohm is recommended). Microphone has polarity - attention for connection.

1.6 Connection SwitchBoard

Switch board is simply device for communication between machine room and lift cabin.

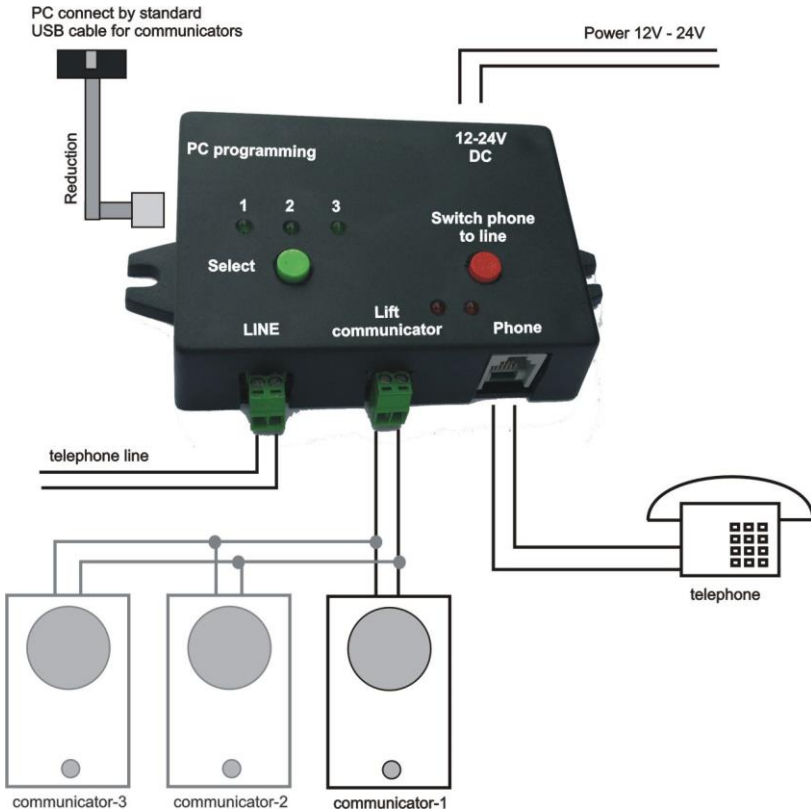

1.6.1 Wiring SwitchBoard

SwitchBoard is connected between the telephone line and lift communicator (only two wires). For correct function, just more connect 12V or 24V DC. Power is independent of the polarity. Consumption is 10mA in an inactive state, at communication consumption is 200 mA at 12V and 150 mA at 24V.

1.6.2 Functions SwitchBoard

So that SwitchBoard worked with connected communicators, they must have some programmable parameters. Switchboard can be used to connect one elevator communicator (single mode) or for 2 or 3 parallel connected Communicators (parallel mode).

Single mode:

In this mode, only two important parameters: disable **parallel connection** and **call duration**. These two parameters must be set in the SwitchBoard as well as in the elevator communicator. It is also necessary for the correct function a set same character prolongation call duration and code for hanging communicator.

Indication: Green *LED 1* flashes, green button does not respond.

Function: After picking up handset of the telephone is disconnected telephone line begins to ring and then lift communicator pick. Normal call progress. Whenever is allotted time to expire maximum call duration,so Switchboard automatically dial the prolongation character. If you hang up the phone, so to the communicator will send hanging code.

Parallel mode:

In this mode it is necessary to set the same parameters in the SwitchBoard and connected communicators. Without this, you can not synchronize operation. These are the parameters: 42 character prolongation, 43 hangup code, 45 activate parallel mode, 4 * constant time detection, 51 maximum call duration.

Indication: Green *LEDs* light, green button switch address where do will be called. Switches in the order 1 / 2 / 3 / 1+2 / 1+2+3.

Function: Select the address (by green button) where do will be called. After picking up handset of the telephone is disconnected telephone line begins to ring and parallel connected communicators gradually pick up and Switchboard selects the desired communicator. Normal call progress. Whenever is allotted time to expire maximum call duration,so Switchboard automatically dial the prolongation character. If you hang up the phone, so to the communicator will send hanging code.

Red button:

Red switch enables the possibility to connect your phone in the machine room with external line. This is mainly for safety reasons, to call for help (ambulance, fire brigade). If the switch is closed, so the external line is connected directly to the phone and communicators in the elevator is not working.

Call from cabine to Machine room:

From version V3.4 of firmware is possible call to the machine room. For call use not blocked ALARM2. This Button has three function:

4. emergency call – press ALARM2 longer than time parameter 52 (2sec)
5. technical call – přes ALARM2 longer than (time param. 52) x 8 (16sec)
6. cal to the machine room – three times press button ALARM2 (explain in picture)

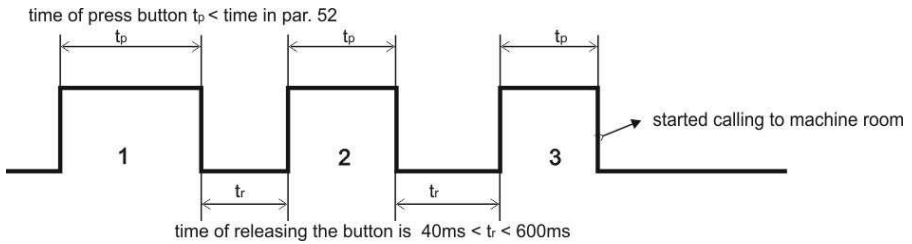

Picture explain how pressed button for successful call to the machine room.

Wiring Reduction
for connection
SwitchBoard to PC



1.6.3 Programming SwitchBoard

SwitchBoard is possible programming only from PC, from program BLCL-konfigurator. Connector for PC has only 4 pins and we need use reduction between 4 pins connector and standard 10 pins programming connector. Programming is easy, in program BLCL-konfigurator we have settings for connected communicators and now we connect SwitchBoard, and write this parameters (without changes) to the SwitchBoard, so this is all. This settings we recommended save to the PC for next other possible future servicing.

Programming BLCL Switch need if you want to maintain good cooperation with connected BLCL. Constants at the BLCL, which will be connected to the Switch BLCL, must mutually agree. Therefore, the following procedure is recommended after setting parameters in BLCL connect via the reduction BLCL Switch and write the same parameters in BLCL Switch.

Parameters affected thereby:

- 42 - Character to prolong the call
- 43 - Command to hang up communicator by phone
- 45 - Activation parallel mode of communicators
- 4* - Constant for parallel mode - time for receive DTMF address of communicator
- 51 - Maximal call duration



If you keep these parameters in the basic setting in BLCL, it is not necessary to program the Switch Board!

1.7 Connection Talker module

Talker module is small module with three permanent messages. Connect the module to the PC connector on BLCL by special cross flat cable.



Talker module contain three messages H1 – H3:

- H1 is message after dial DTMF (time to the pickup country part the message is repeat)
- H2 is message after begin the speak (green LED is light), the message is play only one. This message can be invoked at any time the conversation by DTMF dial * # # (Message H2 must be allowed in par. 01).
- H3 is message befor hangup the communicator (the message is play only one)

The module Talk is possible programming (record the messages) by **special USB cable from PC (include power supply for module)**. Record the messages we prefer by programator in production because recording via USB cable takes a long time and it is not pleasant. Therefore, it is recommended to only record the following message about the installation place of elevators and other reports let predefined.

For the record there are two ways - either send text (s) and e-mail messages in the ALPHATECHTECHNOLOGIES processed and sent back as a WAV file, this file is used in the program BLCL-konfigurator. Another possibility is that the WAV file you create yourself (8bit, 11kHz, mono) and upload to the Talker module.

The maximum length of messages are:

H1 - 1,6sec

H2 - 2,2sec

H3 - 2,2sec

H4 - 5,5sec

Talker is connected only with a special flat cable (crossover) into the PC for programming BLCL. Once connected, you must still select which messages are played (parameter 01). Programming BLCL Talker module in the same USB cable (cable phone) and the same program - BLCL-konfigurator

- Attention USB cable for recording messages to Talker module contains the external power switch - Power Talker module during programming.

Talker module can only be connected to the communicator and self BLCL is broken, it is only optional module.

Part of the module is a flat cable.



Attention, USB cable with the power switch for programming always use as follows:

Position Off - The standard USB cable using as before (Talker module can not be programmed)

Position On (power) - programming of all devices **not connected** to other circuitry (especially to a phone line)

!! for programming BLCL connected to the telephone line and the **On** position of the switch **can damage** the PC, BLCL and PBX!!

1.8 Installation

The compact solution of BraveLiftCallLine enables easy installation into lift cabin panel. Dimension and installation holes are described on pictures.

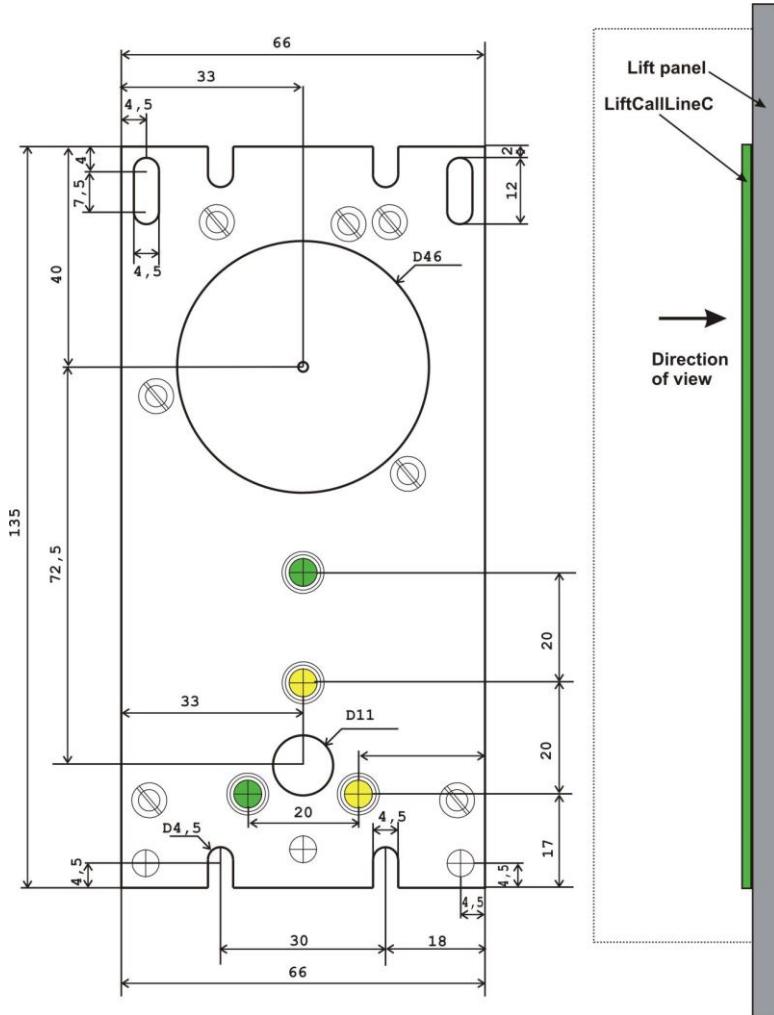

View is to the bottom side of panel in the cabin. The lift cabin panel should be equipped by acoustic holes in microphone, speaker as same as LED indication part.

1.9 Acoustic path setting

The principle of setting acoustic paths:

There are three parameters 71, 72 and 73. Interaction of these parameters influences the audio performance in various environment conditions.

- in a quiet environment, the parameters 71,72,73 are set to value 7
- in an environment where there is a strong ambient noise at the communicator and quiet environment at the phone, it is necessary to reduce the microphone's gain (for example the parameter 72 = 1-3) and also change the ratio of the parameters 71/73 in a way that value 73 increases (for example the parameter 73 = 11-15) and the value of 71 parameter decreases (71 = 2-4)
- in an environment where there is a strong ambient noise at the phone and a quiet environment at the communicator. In this case we keep the value of parameter 72 = 7 and 73 and 71 parameters should be set as follows, for example: parameter 71 = 11-14 and 73 = 2-4

The principle of setting of the parameters is the following:

the signal from the microphone is amplified by the sum of parameters **72+71 = volume of microphone** and the signal to the speaker is amplified by the sum of parameters **71+73 = volume of speaker**. Switching the direction of the ratio is evaluated by parameters 73/72 ratio (**threshold**).

If the value of the parameter 72 is greater than the value of the parameter 73, then we are favoring the direction from the microphone. This is for cases when the audio direction to the phone is being interrupted.















If the parameter 73 is greater than the parameter 72, then we are favoring the direction to the speaker. This is for cases when there is an interrupted sound in the speaker of the door phone communicator.

2. LiftCallLine service

Functionality of BraveLiftCallLine lift intercom is adjustable by parametres settings (via. Programming parametres capture page 40).

2.1 Signalling overview

The BraveLiftCallLine lift intercom signalling acoustically stages which are happening during operation. Samples of acoustical sounds you can play in BLCL-konfigurator (PC programm).

Stage	Tones	Tone frequency
Line pick up (OFF HOOK) type 1		980-1333-1650
Line hang up (ON HOOK) type1		1650-1333-980
Line pick up (OFF HOOK) type 2		800-1067-1200-1333
Line hang up (ON HOOK) type2		1333-1200-1067-800
Command confirmation by phone		800
Alerting (knocking) into call		
Call ending alert		1333
Relay activation signal		Modulovaný
Programming enter by phone		980-1067-1180
Programming by phone		Moduled
Parametr confirmation		800
Programming enter by PC		980-1067-1180
Line connection (Reset)		1850-1067-1850
Error (generally all incorrects)		800
Memory empty (no number programmed)		1300-2100

During problems identification is very good when you know the tones. It helps you monitor how communicator works and where from comes the problem. The signalling might be switch of in a few levels (*parameters 61,62 and 63*).

2.2 Calling from BraveLiftCallLine

Communicator BraveLiftCallLine offers several types of calls. Calling differs by phone number to which the calls and at technical calls are still distinguishes species using DTMF signals. The principle of all calls is that the selected phone number to call, you can choose to use the automatic status or using confirmation code. In addition to the five acknowledgment (confirmation code for each is different reactions communicator) is still the query sequence * # * on the communicator responds (DTMF) what type of call it is (see chapter 2.2.8).

The communicator can be connected expansion module Talker message, if enabled in the parameter 01 message H2 so the DTMF dialing * # # the message is played back on the localization of the communicator.

2.2.1 Emergency call (button activation)

The emergency call is basic and most important feature of BraveLiftCallLine. It is activated by button pressing (connector ALARM2 or ALARM). Button ALARM2 is for directly call (without filtering by FILTER signal), button ALARM is possible blocg by signal on connector FILTER. For each button input is possible set different time for activation the emergency call, common setting is a kind of polarity of the (NO or NC system).

To provide correct functionality for **ALARM** you must keep 2 conditions:

First condition is that, button filtering is not active. Please note that filtering might be either by close contact or by open contact of switch connect to the connector FILTER.

Second condition is that button ALARM you must hold enough time. It is adjustable from 0,5 sec to 39 sec.

To provide correct functionality for **ALARM2** you must keep 1 condition:

Condition is that button ALARM2 you must hold enough time. It is adjustable from 0,5 sec to 39 sec and not hold longer then 8 x parameter 52 (therefore then it is technical call)

Common condition in parallel mode connections is free line. The BraveLiftCallLine measure the voltage on the line and if it is simultaneously picked up other telecommunications equipment (another parallel BraveLiftCallLine communicator) so the line not pickup and not calling.

During emergency call is active both way voice communication. During establishing call is lighting yellow indicator . After call connection – call confirmation – green indicator light up.

Emergency call dial progressively stored numbers (1+6 position). It starts from position 1 up to position which is not programmed. It means when you programm numbers to all 6 position then progressively dial all 6 numbers. When you erase number on position 3 then dial numbers on position 1 and 2 and returns back to position 1. You can also programm how many times the round (programmed numbers on position 1-6 should be repeated (1 to 9 times). While

is emergency call the button does not react on other pressing and even more any other stage might not break emergency call procedure.

The last point of emergency call is call confirmation . At every emergency number (position 1-6) you can select confirmation or not.. Dialling is stoped after call connection (confirm call = light green LED indicator).

Endo of alarm is function for fitters - if fitter is on place - on lift, so he confirm this event as Endo of alm - you must press button ALARM2 longer then 8 x parameter 52, next is call is technical call - End of Alarm.

2.2.2 Emergency call with cancelation (Alarm button)

For button ALARM (Emergency call with function blocking - FILTER) is possible use method call with a time blocking. Use them where there is no proper signal for blocking calls from the system electronics elevator. Blocking be on the principle movement of the door. If you press the alarm button and to the programmed time (par. 02) no signal blocking FILTER (change) so he makes a call. When the doors open at this time (cab reached the destination) and the call from the button cancels and nowhere is calling.

Advantage - simple principle of blocking

Disadvantage - delays call from the button alarm for time (par. 02)

2.2.3 Service calling (from timer)

Service calling is optional parameter. You also define if this parameter is activated since first connection of BraveLiftCallLine to telephone line.This service calling is adjustable from 1 to 59 day period, for example 03 means that BraveLiftCallLine is make automatically every 3th day a call to preprogrammed number. (test of BraveLiftCallLine functionality).

For service calling you programm special number which might be of course the same as emergency calling number. You can also select if will be dialling only this number or all round of emergency numbers (then you have max 7 numbers) .

The service calling is repeated in period 0-9 min (programmable) until succesfull call (confirmation). The repeated time between calls is programmable because to service department can call more BraveLiftCallLine. To avoid of problem that service department line is busy you can programm different time period for service calling up installation place.

During failure calling is not lighting any indicator. It is not voice communication.

Automatic test acoustic path - automatic function requires activating "function call service" and enabling service automatic test acoustic path. Otherwise, you can invoke the service confirmation (**par.07**) with instantaneous start the service call (this is done only when it is on, but the test is performed acoustic paths). Detail about the error in the acoustic path get technical call with the code "0" (test with * # *).

2.2.4 End of calling – call confirmation

The BraveLiftCallLine enables to program at every number if will be confirm or not. Every call needs authorisation if it was succesfull or not. Therefore analog line doesnt support any kind of authorisation (signalling) we can define success of call by 2 ways. The BraveLiftCallLine needs this info to not dial further telephone numbers.

First way (**no confirmation**) is detection that call was succesfull on the base control ringing tone (CRT). It is tone which we are hearing in handset when make call to other subscriber. Thed BraveLiftCallLine detects this tone and when is missing for certain time then evaluate the call was succesfull (Green indicator light up and yellow light down). The time which define undetection of CRT (called part picks up) is adjustable because each type of PBX can be different. Usually should be 5 seconds as the best (parameter 56). At this call authorisation stays possibility confirm the call by dial confirmation characters (kxxxx, where xxxx is 1-4 numerals). After dialling of confirmation characters BraveLiftCallLine reply and reactions are four possibilities for the confirmation of four different confirmation codes - specified below.

Second way (**with confirmation**) is detection that call was succesfull only by dial confirmation characters (kxxxx, where xxxx is 1-4 numerals). This way is most reliable but requires trained people in service department (they must be able insert confirmation characters when call is pick up), or at service department must be used evaluation software. After dialling of confirmation characters the BraveLiftCallLine reply and reactions are four possibilities for the confirmation of four different confirmation codes - specified below.

Types confirmation codes (all is same principec - call kxxxx where xxxx is 1-4 numerals - numbers 0-9):

- **par. 47** - return DTMF serial number of the BraveLiftCallLine lift communicator. By this way is detected where from is coming a call even when more BraveLiftCallLine is installed behind PBX. In this case is not possible detect it by CLIP because all BraveLiftCallLine communicators have the same CLIP due the same telephone line use for outgoing calls. The same is the case with parallel connection communicators in one telephone line.
- **par. 48** - return DTMF state of counter of move lift cabin. This parameters is on Option module!
- **par. 49** - react on this confirmation is hangup and dial Emergency call like as after press bytton ALARM2 (without function of filtering)
- **par. 40** - return DTMF last two dial numbers (separate by special DTMF tone "D"), first is last and second is pre last dialing telephone numbers
- **par. 07** - react on this confirmation is hangup and dial Service call like as after time expires for Service call (must be set Service call (par.31) and call is after timeout for Service call (par. 32)

Character k is common first character (0-9,*,#) for all four type of confirm code. The last possibility to call confirm is dial hangup code (parameter 43).

2.2.5 Machine room connection

Connection between machine room and BraveLiftCallLine is same as normal connection telephone line - two wires. In Machine room is equipment powered from 12-24V (switchboard), which allows the connection of the telephone line, the telephone and one to three parallel connected communicators. The reason is that during machine room communication is disconnected telephone line. The BraveLiftCallLine accept machine room call as incoming, it means you can program the unit, control outputs/ inputs. The call is normal time limited and prolong is automatically from SwitchBoard by DTMF.

The call is activated by picking up of phone. The BraveLiftCallLine picks up immediately (if you use one communicator) or after address decode - parallel connection (2-3 communicators parallel connection). This status is indicated by green indicator. You can make voice communication. The call duration is in parameter 51. Switch board is programmable device and for right function is need program same parameters to the BraveLiftCallLine and to the SwitchBoard.

As new feature is possibility call directly from BraveLiftCallLine to the machine room. This call is made from ALARM2 button – three times press the button.

2.2.6 Incoming call

Incoming call is coming from outside to BraveLiftCallLine. After extension dialling or land line number where is BraveLiftCallLine connected the BraveLiftCallLine is ringing and after preprogrammed number of rings (parameter 46) the BraveLiftCallLine picks up and you can speak to lift cabin.

Exceptional is first 10sec, where is additionally possible insert "# and service password" (*parameter 44*), to enter programming mode.

When jumper "SERVIS" on BraveLiftCallLine basic board is closed you are automatically going to programming mode when call is picked up. (without service password). It is useful when you forget service password and by this way you can program the new one. Do not forget disconnect jumper after programming. Jumper is on the basic board (page 8).

Incoming call is detected by green indicator. It is possible voice communication. After confirmation by code behaves the same as described in chapter 29.

LiftCallLine lift communicator enables a special mode - **parallel connection** of several communicators. More about in the next chapter.

2.2.7 Parallel connection BraveLiftCallLine communicators

In this mode (parameter 45) is the outgoing call control voltage telephone line and for incoming call here the system is addressing DTMF which communicator should stay pickpuped. Therefore it is important to set the number 1-5 for communicator communicators connected parallel (parameter 46). Among the numbers must not be a space. For 3 parallel connected is only right to set the communicators numbers 1-2-3. 1-3-4 or 1-2-2 settings are not correct!

The whole system works by detection the ring (connected in parallel in all communicators) rises first line first and immediately notify the DTMF dial own number i.e. 1 He is waiting for confirmation own number 1 pick up if and if does not detect own number 1 or not to accept nothing he not stay so pickpuped. On the detection is reserved time in 0.1 seconds - default 2,5sec (parameter 4 *). After this time next pickup communicator, which is reported as 2 (DTMF) and the first communicator either hang up, or stays off the hook. This method ensures that at the time of detection is connected to the line is always one communicator, so there is no distortion of detection. If disagree received numbers With each communicator with the number of communicator, so the time constant of $5 \times 4 *$ parameter, the line will be hanging and not connection is established. If it matches the number one communicator and the communicator remains pickpuped and after the time constant of $5 \times 4 *$ parameter to communicator works the normal way.

Calling in a parallel connection is follows - you want pick up Communicator 2:

- dial number of line which are parallel communicators
- first picks up communicator 1 and you will hear DTMF 1
- confirm the dial DTMF 2
- picks up the communicator 2 and communicator 1 hang up
- second communicator is register DTMF 2
- confirm the dial DTMF 2
- picks up the communicator 3 and communicator 2 not hang up
- third communicator is register DTMF 3
- confirm the dial DTMF 2 (optional)
- communicator 3 hang up and communicator 2 is still pickpuped time $2 \times$ constant parameter 4 *
- communicator 2 is works as a normal incoming call, ie you will hear a tone pick-up communicator and for 10 seconds to enter the programming mode

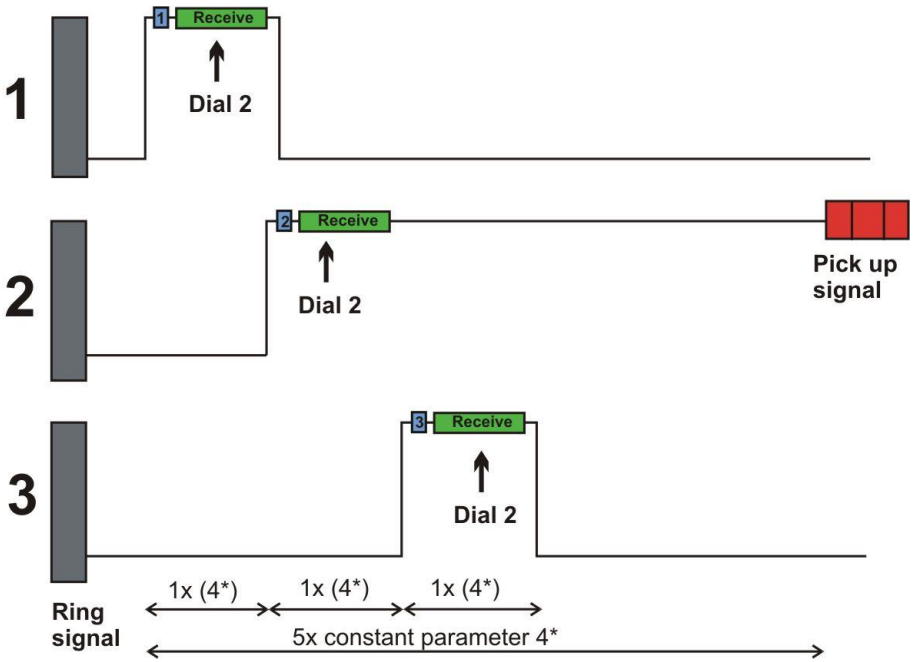

2.2.8 CallCentrum and types of calls

In Call centrum is fix code ***#*** for identification call. This code can query the type of call. Code *** # *** is dial by DTMF and BraveLiftCallLine communicator response sends one character what kind of call is in progress. This is mainly use for technical calls when one phone number are three types of call.

Type of call	returned DTMF character
Emergency call:	1 – 6
Service call:	8
Option module counter from INP3:	9
Technical call:	A
- end of Alarm	A
- cal from combination inputs (option module) where D is separator, aaaaaaaa is change to active of 8 inputs on Option module, nnnnnnnn is change to inactive of 8 inputs on Option module and iiiiii is state of 8 inputs on Option module	BaaaaaaaDnnnnnnnnDiiiiiii
- call from not move cabine (option module)	C
- call if acoustic path is bad	0
- call if is permanent activate button	7
- call engineer arrived at the elevator	**
- call engineer has left the elevator	*#

2.2.9 End of Alarm

One type of the technical call is to confirm processing emergency call in place (in the lift cabin). This call can be done by holding down Btn.1. This button is not filtered by BraveLiftCallLinefilter signal. The minimum holding period is a button 1 in parameter 52 , for example this time is 1sec, next function of this button is:

- time of hold ALARM2 is lower then 1 sec = no dial
- time is between 1sec and 8sec (resolution is 8times for easy programming) = dial emergency call
- time is longer then 8sec = dial technical call - call "end of Alarm"

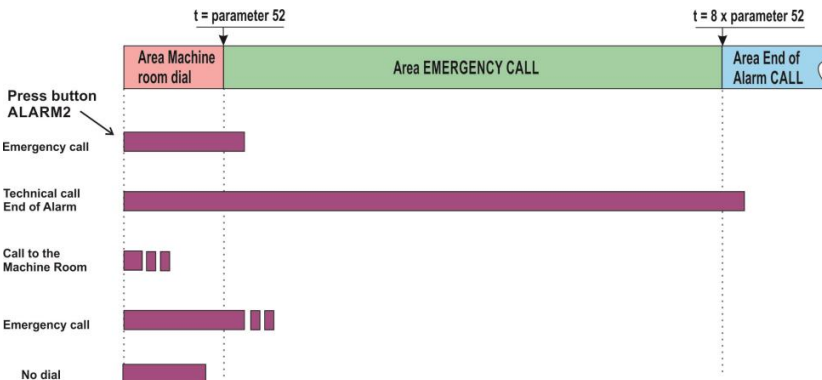

3. Parameters programming

3.1 Programming by telephone:

3.1.1 Enter to programming mode

The BraveLiftCallLine will be set to programming mode in two ways:

1. **by password** – only incoming call! – answer the telephone and dial a number, where the BraveLiftCallLine is connected (*either extension number, if connected to PBX or number of state line to object, where the BraveLiftCallLine is placed and let you put through to PBX directly connected with BraveLiftCallLine*). The BraveLiftCallLine will answer (you hear tone for answering – see table on page 26) up to 10 sec dial **#xxxx**, where xxxx is the service number for entry to programming and if O.K., the registration tone to programming will sound and afterwards the programming tone is heard (see Table on page 26). Default settings is password xxxx=**0000**
2. **by "SERVICE" jumper** – only incoming call! – you will realize the connection with BraveLiftCallLine in the same way as in point. 1, but when the SERVICE jumper is connected, then the BraveLiftCallLine after answering directly comes to programming mode – you hear tone for answering, registration tone to programming and afterwards the programming tone is heard. (see table on page 26).

3.1.2 Programming of parameters

The initial state for programming is signaled by programming tone and the BraveLiftCallLine will come back to this state always after time expiration (5 seconds) even you started to program anything.

When programming two types of parameters will occur. Partly they are parameters with **fixed length** – the majority of them they are, then the programming is affirmed and the parameter is always recorded immediately after mandatory length fulfillment by acknowledge tone and partly the parameters **with variable length** (*parameter 1,2,47-40*), followed with **confirmation** and the recording of the parameter after inactivity period expires (5 sec). The only case with immediate recording of parameters is the fulfillment of max. number of recorded signs (numbers) – by parameters 1,2 it is 16, by parameter 47-40 it is 4.

If during programming you enter number (sign) not allowable by its extent then the BraveLiftCallLine immediately emits an **error tone**, the parameter will not be recorded nor changed, the BraveLiftCallLine will come to initial state and it is possible to repeat the parameter setting or program another parameter.

The BraveLiftCallLine stays inactive in programming mode for 30 seconds, then he will automatically hang up. By every dialing of DTMF tone this period is set up repeatedly. The selection of parameter 9 can also end the programming mode.

Note 1. if you wish to keep the connection (extend the 30 seconds period) than the customer will think over the other setting, so pressing e.g.. * or # form time to time will be sufficient and the BraveLiftCallLine immediately responds by error tone, but he will extend the period to hanging up..

3.2 PC programming– programm BLCL-konfigurator

For setting of BraveLiftCallLine by PC you need special USB cable KAB with galvanic isolation included and Programm BLCL-konfigurator. The BraveLiftCallLine must be connected to telephone line – powering.

Procedure:

- Connect the BraveLiftCallLine to the line
- Connect the BraveLiftCallLine with PC by USB cable. The BraveLiftCallLine will answer and LED indication light.
- Run the BLCL-konfigurator program – the BraveLiftCallLine will report the his conversion to PC programming mode. After BLCL-konfigurator program being run the BraveLiftCallLine is in this mode – this status is indicated by LED light on panel by 1 second flashing. By loss of connection it is necessary to disconnect the cable from BraveLiftCallLine connect it again – the BraveLiftCallLine will answer and if BLCL-konfigurator program runs he will report his conversion to programming mode. In BLCL-konfigurator program is this connection indicated in upper riht corner.

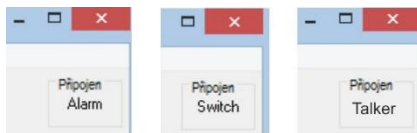

For setting **Option module** by PC you need special USB cable KAB with galvanic isolation included and Programm BLCL-konfigurator. The Option must be connected to 12V.

Procedure:

- Connect the Option with PC by USB cable. The Option will answer and yellow LED indication light.
- Run the BLCL-konfigurator program – the Option will report the his conversion to PC programming mode. After BLCL-konfigurator program being run the Option is in this mode – this status is indicated by yellow LED - 1 second flashing. By loss of connection it is necessary to disconnect the cable from Option connect it again – the Option will answer and if BLCL-konfigurator program runs he will report his conversion to programming mode. In BLCL-konfigurator program is this connection indicated in upper riht corner.

3.2.1 Install program BLCL-konfigurator

Program BLCL-konfigurator instal to platform Windows only and supported system W98SE-W7-W8 /32-64bits

Procedure:

- if you download program from WEB sites, so need is unpack from archive package ZIP
- click on setup.exe
- select your language and follow the instructions of the installer
- on your desktop is icon of BLCL-konfigurator, click of this and use program.

. For USB cable is necessary instal driver for USB cable. Install is standard driver installation - plug in cable, system Windows ask on driver, you select path to the driver and klik OK/YES.



Driver is not signed electronically, it must agree with the installation In Windows 8 is need allow the installation of unsigned drivers.

Program BLCL-konfigurator with USB cable is also used for firmware upgrade Program and driver is on CD or on WEBSites your seller.

In BLCL-konfigurator program is indicated connection in upper riht corner:

- Alarm
- Switch
- Talker

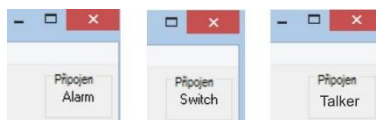

Numbers before the names of the parameters in the program BLCL-konfigurator when programming parameter codes from phone using DTMF. This is immediatly clear which the parameter they are and easily find his explanation in the next chapter Parameters description.

3.3 Remote programming from PC

Program for settings parameters of communicator from Version V3.0 and from version of firmware in communicator allows remote programming by using DTMF modem BlackBox.



DTMF transfer is not 100% reliable, so it is recommended that changes in Communicator check by reloading the values.

3.3.1 Procedure remote connection

Click in the main menu on Remote and next click on the Connect to communicator.

Firstly select the BalckBox, which you need use for remote communication with communicator. The BlackBox is can not be used in same time for CallCentrum.

For next step you must fill the telephone number of communicator and password in communicator for programming. Number of communicator fill only if you call to parallel connected communicators. If you firstly read file with settings for the communicator, password will be prepared automaticly. Long time for GSM use if in communication trace is include GSM gate.

in the main menu are added two new items - number of BlackBox (CALxxxxx) and info, that communicator is connected (Connect). Information value of connection - click on the number BlackBox to display the time connection with the communicator and click on Connect displays the number of prolongation connection (counter).

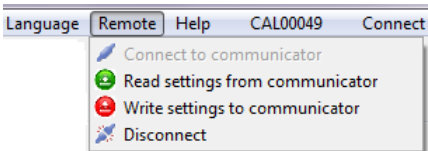
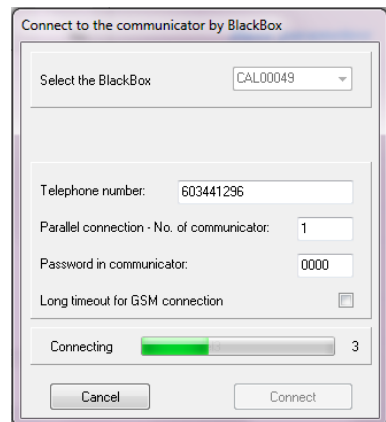
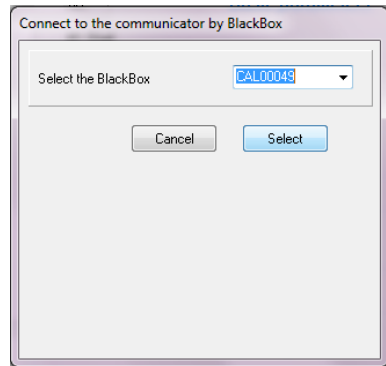
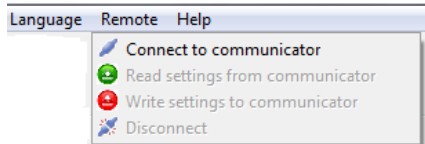

Now is possible read or write settings from communicator.

3.3.2 Read settings remotely

Communication is by DTMF and for one byte of data is use two DTMF tone. This communication is slow and therefore you can choose which part of the communicator data to read. The whole process of reading the data it is possible to log to a log file, and when any problem send the file by e-mail.

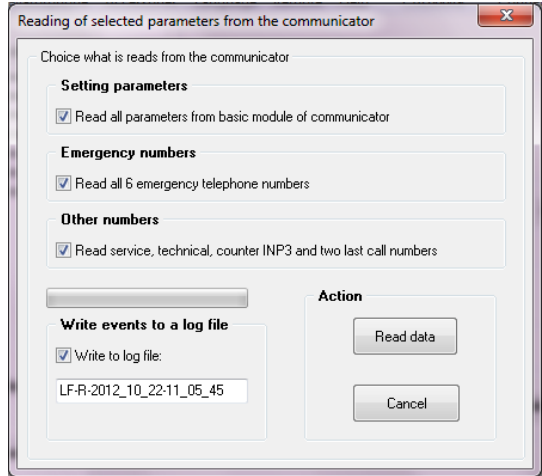

3.3.1 Compare reading value

To ensure the secure transmission of the remote setting is recommended for this procedure: First original data of the specified communicator you should be stored on the PC Second make a change the parameter value Third save it back to the PC 4th remote write in the communicator 5th read remotely from the communicator 6th use the service to compare and see if the parameters are all right write in the communicator Compare in PC program compares the read data remotely from the communicator to the data which are currently in the PC program. Filtering allows invisible data which are systemic (which may vary). On the right side displays only those parameters that are different.

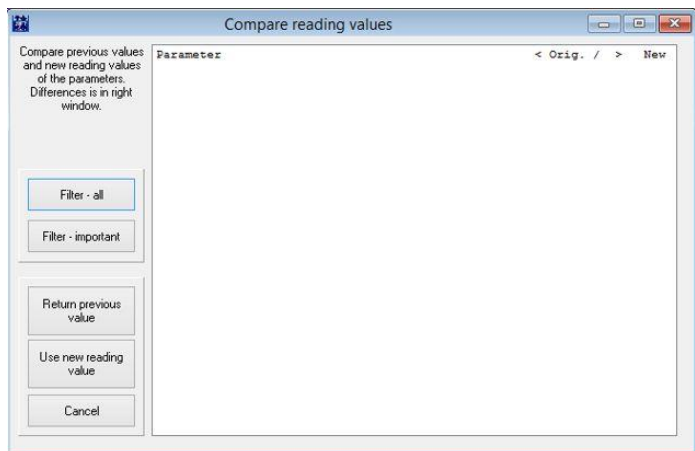
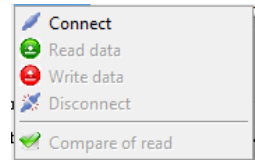

3.3.2 Write settings remotely

Communication is by DTMF and use normal directive for programming same as programming from Phone. This communication is slow and therefore you can choose which part of the communicator data to write. Other data do not replace and remain original. Unable to remotely delete the number of resets, time service call and last dialed numbers. The whole process of reading the data it is possible to log to a log file, and when any problem send the file by e-mail.

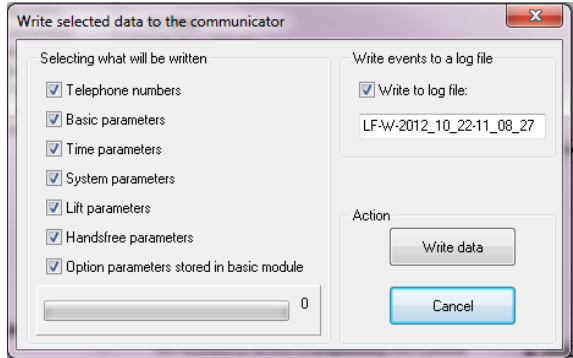

4. Parameters description

4.1 Phone numbers memory

Emergency numbers (button activation)

Parameter	Value	Description	default
1	tp nn...	number nn in order t with confirmation p	-

t – memory order of number, programm [1-6] digits only

p – call confirmation, programm [0-1] only,
0-confirmation OFF, 1-confirmation ON

nn – telephone number up 16 digits. To programm other characters look on table.

Basic setting as same as examples setting not change or erase those saved numbers.

note	dial
0 - 9	0 – 9
#	#
*	**
Flash	* #
Pause	* 0

Example: You want on the first place dialing a phone number **0P213658 without confirm** and on second place **54*23#78P91F4 with confirm** so programming sequence: 110 **0*0213658**, waiting tone, 121 **54**23#78*091*#4** and waiting tone

Example: **Erase** the telephone number on second position - so programming sequence is **12** and waiting tone

Service number (system timer activation)

Parameter	Value	Description	Default
21	p nn...	Number nn with confirmation p	-

p – call confirmation, programm [0-1] only,
0-confirmation OFF, 1-confirmation ON

nn – telephone number up 16 digits. To programm other characters look on table.

Basic setting as same as examples setting not change or erase those saved numbers.

note	dial
0 - 9	0 – 9
#	#
*	**
Flash	* #
Pause	* 0

Example: You want dialing a phone number **0P123456789 without confirm** so programming sequence: 210 **0*0123456789** and waiting tone

Example: **Erase** the telephone number - so programming sequence is **21** and waiting tone

Technical number

Parameter	Value	Description	Default
22	p nn...	Number nn with confirmation p	-

p – call confirmation, programm [0-1] only,
0-confirmation OFF, 1-confirmation ON

nn – telephone number up 16 digits. To programm other characters look on table.

Basic setting as same as examples setting not change or erase those saved numbers.

note	dial
0 - 9	0 – 9
#	#
*	**
Flash	* #
Pause	* 0

Example: You want dialing a phone number **F789 with confirm** so programming sequence: 221 *#789 and waiting tone

Example: **Erase** the telephone number - so programming sequence is **22** and waiting tone

4.2 Lift operation

Parameter	Value	Description	Default
31	a	Service calling is in status ON / OFF (0/1/2)	0

a – **0** service calling OFF

– **1** service calling ON after time set in parameter **59**

– **2** service calling ON after time set in parameter **59** and moreover is activated during first telephone line connection

service calling is activated after time set in parameter **59** and is repeated after time period set in parameter **32**. Repeat the service call is in parameter **38**

Parameter	Value	Description	Default
32	h	Period of waiting in service call [min]	4

h – **0** service call repeat immediately

– **1 ÷ 9** service call repeat after 1-9 min

Parameter	Value	Description	Default
33	i	Polarity of buttons ALARM (0/1)	0

i – **0** buttons connected is type NO - normally open (parallel connection)

– **1** buttons connected is type NC - normally close (serial connection)

Use only contact without voltage potential, can be used NO or NC contacts.

Parameter	Value	Description	Default
34	z	Polarity of FILTER input (0/1/2/3/4)	0

z – **0** filtering activate by shorting input (NO contact)

– **1** filtering activate by opening input (NC contact)

– **2** filtering activate by shorting input (NO contact) and send information of state input BLK

– **3** filtering activate by opening input (NC contact) and send information of state input BLK

– **4** filtering is disabled and FILTER input is for send information of presence the engineer in Lift cabin

Use only contact without voltage potential, can be used NO or NC contacts.

Parameter	Value	Description	Default
35	b	Number of repeat sequence emergency call (1-9)	3

- b** – 1 ÷ 9 times is repeated dial of emergency numbers (button pressing).
Emergency numbers are dialled from first position until empty or 6th position. This is 1 sequence. It might be repeated max 5 times.

Parameter	Value	Description	Default
36	c	Number of repeat technical call (1-9)	1

- c** – 1 ÷ 9 times is repeated dial of technical numbers (Option module - inputs state is change)

Parameter	Value	Description	Default
38	ee	Number of repeat service call (00-99)	00

- ee** – 00 - unlimited, service call is repeated until the call is confirmed [2 digits]
– 01 ÷ 99 times is repeated dial service numbers (Service call is from internal timer and begin ones on 1 - 59 days - parameter 59)

Parameter	Value	Description	Default
39	i	Polarity of buttons ALARM2 (0/1)	0

- i** – 0 buttons connected is type NO - normaly open (parallel connection)
– 1 buttons connected is type NC - normaly close (serial connection)

Use only contact without voltage potential, can be used NO or NC contacts.

4.3 Basic parametres

Parametr	Value	Description	Default
41	v	Dial type v – tone / pulse (0/1)	0

v – dial type v=0 is DTMF tone dial, v=1 pulse dial

Parametr	Value	Description	Default
42	z	Character to prolong the call (* / #)	*

z – character to prolong the call * or # (10sec before call termination communicator sends notification then you can prolong the call)

Parametr	Value	Description	Default
43	bb	Command to hang up communicator by phone (00-99,*0-*9)	44

bb – command to hang up communicator by phone [2 digits] /¹

/¹ – command has always 2 digits but if you want use **1 digit** then you have possibility insert " *a " where **a** is just one number which hang up line (star represents empty character and must be on first position).

Parametr	Value	Description	Default
44	xxxx	Service password (0000-9999)	0000

xxxx – service password to enter programming by phone (DTMF) [4 digits]

Parameter	Value	Description	Default
45	p	Activation parallel mode of communicators (0/1)	0

p – 0 parallel mode is disabled

– 1 parallel mode is enabled, it's possible connection up to 5 communicators parallel on the telephone line

Parameter	Value	Description	Default
46	n	Number of rings before pickup or number of communicator in parallel mode (1-5)	3

n – 1 ÷ 5 in normal mode is number of rings before BraveLiftCallLine pickup line, in parallel mode is n representation number of communicator.

Parameter	Value	Description	Default
47	eeee	Confirm code, BraveLiftCallLine return serial number (0-9999)	66

eeee – Confirm code - confirmed call, BraveLiftCallLine return DTMF serial number after receive this code. [1-4digits]

This code is dialed to the call from telephone or from Call centrum, this confirmation authorize call, LED yellow is light off and LED green is light on. You can use 1 - 4 digits long code, but before code you must dial common character **k** (parameter 4#)

Parameter	Value	Description	Default
49	oooo	Confirm code, BraveLiftCallLine answer redial emergency telephone numbers (0-9999)	68

oooo – Confirm code - confirmed call, BraveLiftCallLine hangup and dial emergency number(s) like as press ALARM2 (without filtering). [1-4digits]

This code is dialed to the call from telephone or from Call centrum, this confirmation authorize call, LED yellow is light off and LED green is light on. You can use 1 - 4 digits long code, but before code you must dial common character **k** (parameter 4#)

Parameter	Value	Description	Default
40	ssss	Confirm code, BraveLiftCallLine return last two dialled telephone numbers (0-9999)	69

ssss – Confirm code - confirmed call, BraveLiftCallLine return DTMF last two dialled telephone numbers (separated by "D" DTMF) after receive this code. [1-4digits]

This code is dialed to the call from telephone or Call centrum, this confirmation authorize call, LED yellow is light off and LED green is light on. You can use 1 - 4 digits long code, but before code you must dial common character **k** (parameter 4#)

Parameter	Value	Description	Default
4*	kk	Constant for parallel mode - time for receive DTMF address of communicator (10-49)	25

kk – 10 ÷ 49 this time is need for answer DTMF address in parallel mode [1-4digits]

Time is in 0.1 sec, 10 is 1sec, 25 is 2.5sec. Explain of this constant is on page 31.

Parametr	Value	Description	Default
4#	k	First character of confirm code (0-9 /* / #)	*

z – first common character of begin confirm code

Rem. confirm code is in parameters: 47, 49, 40, 07

4.4 Time parametres

Parametr	Value	Description	Default
51	d	Maximal call duration (0-9,*,#)	4

d – maximal time for which communicator is OFF HOOK.

This time you can prolong by dial character during a call by phone (* or # - parametr 42). Setting of time is up table.

time[min]	Dial
0,5	0
1 - 9	1 - 9
15	*
UNLIMITED	#

Parametr	Value	Description	Default
52	w	Time of button ALARM2 pressing (holding) for emergency call activation (00-39)	02

w – 00 time 0.5sec for emergency call activation

- 01 ÷ 39 minimal [in sec] time for which must be button ALARM2 hold pressed to start emergency call procedure.

Note: for Technical call is need hold the button ALARM2 longer then 8 x parameter 52

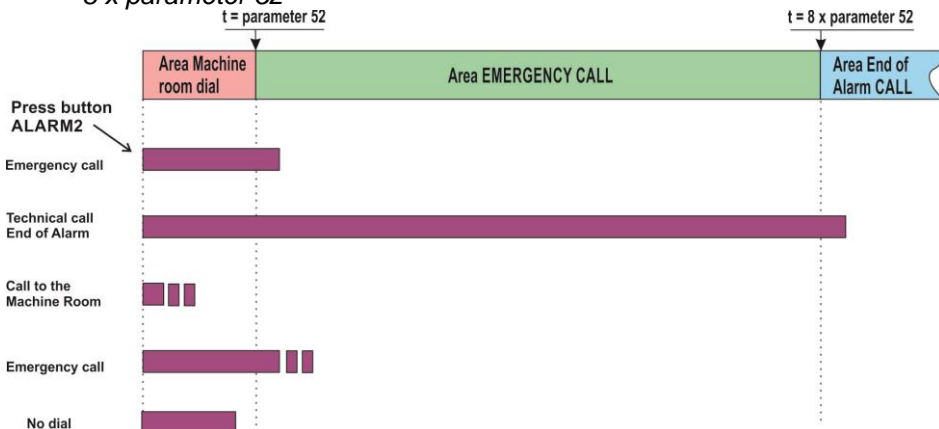

If pushbutton Alarm2 still pressed, so next call is not possible activate

Parametr	Value	Description	Default
53	z	Time of button ALARM pressing (holding) for emergency call activation (00-39)	05

z – 00 time 0.5sec for emergency call activation

- 01 ÷ 39 minimal [in sec] time for which must be button ALARM hold pressed to start emergency call procedure.

If pushbutton Alarm still pressed, so next call is not possible activate

Parametr	Value	Description	Default
54	r	Hanging up time during REDIAL (1-5)	1

z – time [sec] for which communicator hangs up before pick up for REDIAL (button push during call, busy tone detection) [range 1-5]

Parametr	Value	Description	Default
55	s	Time before start dialling (1-5)	1

z – time [sec] after communicator picks up and before start dialling [range 1-5]. This time is different for every PBX but usually all PBXs accept dial within 2 seconds after line is picked up.

Parameter	Value	Description	Default
56	e	Time without ringing tone – call detection (1-0)	5

e – 1 ÷ 10 sec (0 = 10 sec) is time for which is not detected ringing tone after dialling of number. If is set at number dial without confirmation then is set that call started. This parameter significantly determines the correct auto confirmation call. The aim should be to set the smallest possible value.

Example:

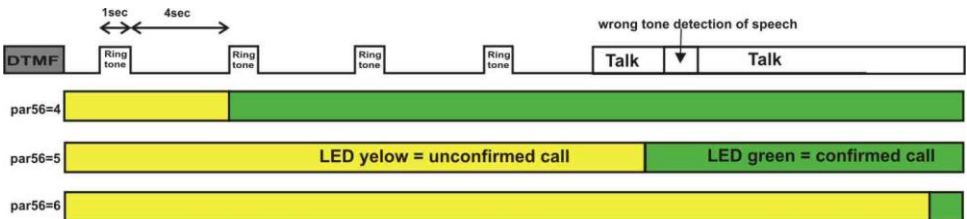

Parameter	Value	Description	Default
57	cc	Time waiting for confirmation [sec] (10-99)	25

cc – 10 ÷ 99 sec is time which after number dialling the BraveLiftCallLine waiting for call confirmation. If to this time call not confirmed (parameters 47-40), so BraveLiftCallLine hangup and pickup and dial next telephone number.

Parametr	Value	Description	Default
58	hh	Number of rings before hang up (04-99)	12

hh – after dial termination calculate number of CRT (control ring tones). When number is higher than **hh** then hang up [range 04-99]. Dial is repeat and dial next number.

Parameter	Value	Description	Default
59	g	Number of days after which is perform service call (1-59)	3

h – [1 ÷ 9 days] after programmed time the BraveLiftCallLine call to service department to notify its full operation (functionality). The time from last call is display in Lift set programm.

Parametr	Value	Description	Default
500	x	Middle frequency of tones detector (1-0)	3 (375-475Hz)
501	y	Number of busy tones (2-0)	4
502	z	Time of permanent tone duration (1-5)	3 (3s)

x – middle frequency of tones detector – is suitable when PBX signalling is unusual:

frequency [Hz]	x - dial
275-375	1
325-425	2
375-475	3
425-525	4
475-575	5
525-625	6
575-675	7
625-725	8
675-775	9
725-825	0

y – minimal number of busy tones necessary for detection [2-0], where 0 means 10 busy tones

z – minimal time of permanent tone duration (for dial tone detection on PBX) [1-5 sec]

Parametr	Value	Description	Default
503	tt	Time of tone duration DTMF (tone) dial (04-16)	10 (100ms)
504	mm	Time of space duration between DTMF tones (04-16)	10 (100ms)
505	f	Time of Flash duration (1-6)	1 (100ms)
506	p	Time of pause duration / pause between numbers (1-0)	4 (800ms)

- tt** – Time of tone duration DTMF (tone) dial is calculated up:
 $(\textit{inserted number}) \times 10 = \textit{tone duration time}$ [ms]
[range 04-16 tj. 40-160ms]
- m** – Time of space duration between DTMF tones is calculated up:
 $(\textit{inserted number}) \times 10 = \textit{pause duration time}$ [ms]
[range 04-16 tj. 40-160ms]
- f** – Time of Flash duration is calculated:
 $\textit{inserted number} \times 100 = \textit{Flash duration time}$ [ms]
[range 1-6 tj. 100-600ms]
- p** – Time of pause duration is calculated:
 $\textit{inserted number} \times 100 + 400 = \textit{pause duration time}$ [ms]
[range 1-0 tj. 500-1400ms]
- time **p** is also time of pause between numbers at pulse dialling

Parametr	Value	Description	Default
507	uu	Level of sending tone DTMF dial in [-dBm] (04-16)	10

- uu** – level of sending tone (DTMF) dial into line, range is -4 to -16dBm. You insert desired level, uu=04 is -4dBm, uu=10 is -10dBm

Parametr	Value	Description	Default
508	p	preemphasis DTMF (0/1)	0
509	S	Listening –in DTMF - level (1-4)	2

- p** – preemphasis is rate between upper and lower groups of DTMF frequency. You can select rate 2,2 dB - p=0 (Europe) or rate 3,2dB - p=1 (Australia)
- s** – listening –in DTMF level you can select in four levels:

Level of listening in DTMF [dB]	s - dial
-15	1
-9	2
-3	3
+3	4

4.5 System parameters

Parametr	Value	Description	Default
61	z	Acoustic signalling (confirmation, error, empty memory, call termination...) (0/1)	1

In default the stages of communicator are acoustically signalling. By parametr „z“ you can switch off this signalling. Possible values are

z=0 – signalling is off

z=1 – signalling is on

Parametr	Value	Description	Default
62	v	Acoustic signalling off hook/on hook (0/1/2)	1

In default is signalling pick up and hang up of the line. If you identify some problems at certain PBXs you can switch it off by parametr „v“. The possible values are:

v=0 – signalling OFF HOOK / ON HOOK is off

v=1 – signalling OFF HOOK / ON HOOK is on (type 1)

v=1 – signalling OFF HOOK / ON HOOK is on (type 2)

Parametr	Value	Description	Default
63	u	Acoustic signalling knocking to call (0/1)	0

In default it is switch off. By activation of this feature you can identify at PBX calling from communicator just up knocking into call. Possible values are:

u=0 – knocking to call is off

u=1 – knocking to call is on

Parametr	Value	Description	Default
64	i	Suppression of DTMF reception from microphone, mute for special call, mute microphone before confirm call (0 – 9,*,#)	0

In default the **suppression of DTMF reception from MIC** is off - **i=0** and **mute for special call** is off **i=0**.

To increase security you can activate **suppression of DTMF** reception from microphone **i=1**, **i=3**, **i=5** or **i=7** and due this protect possibility use communicator commands by unauthorized person (which provided record of DTMF code from speaker and next use for communicator services).

Next function is **MUTE speaker and microphone** for special call - it's meaning service call, technical call and counter call - (**i=2**, **i=3**, **i=6** or **i=7**).

If use the mute for special call, so for all time of call is supress tone sinalization for pickup / hangup line and confirm tone. Next is mute of microphone and speaker for talk and dial DTMF is decrease the volume of speaker to minimum. This calls will be muted:

1. call „service call“
2. call if not OK test audio
3. call if push button is permanent activate
4. call if lift cabin not move (option module)
5. call if counter of maximum set move of cabin is overflow (option module)

Another function of this parameter is **mute, until the call confirmation** (simplified if the green LED and the microphone is active or not - see. Features a green LED and confirmation call). This feature will facilitate communication with the call center communicators in a noisy environment. This function is active when the value of **i = 4, i = 5, i = 6** or **i = 7**. If you select this function, so it is possible prolong the time before activation microphone after confirmation. This feature is solve problem with communication CallCentrum. There is two times of prolong 3sec and 6sec.

Table value of **i**:

value of i	mute for special call off		mute for special call on	
	The microphone is still active	The microphone is active after confirmation call	The microphone is still active	The microphone is active after confirmation call
DTMF reception from MIC	0	4 [+0sec]	2	6 [+0sec]
	-	8 [+3sec]	-	9 [+3sec]
	-	* [+6sec]	-	# [+6sec]
Suppression of DTMF reception from MIC	1	5	3	7



Mute for special call affects the messages of Talker module (if silent call, so Talker module sends no message)!

Parametr	Value	Description	Default
65	b	BabyCall – call without necessity programm phone number (0/1)	0

In default is switch off **b=0**. By activation this feature **b=1** is cancelled acoustic signalling of empty memory. After pushing of button with empty memory you get just beep (confirmation) and call is established as normal dialled number

Caution: first 10sec of call is not active tone detector (it waits on reaction of PBX and number dialling by PBX)

Parametr	Value	Description	Default
6*	t	Delay start for PBX's with line testing (Siemens) (0/1)	0

In default is switch off **t=0**. By activation this feature **t=1** is processor going to „sleep mode“ after line connection and after 3sec the communicator makes initialization. It delays line picks up after line (voltage) connection – activation status / PBX restart.

4.6 HandsFree parametres setting

Parametr	Value	Description	Default
71	gg	Reception loudness 01-16 (16 is highest) (SPK)	05
72	ff	Transmission loudness 01-16 (16 is highest) (MIC)	02
73	rr	Speaker loudness 01-16 (16 is highest) (TRH)	12

gg / ff / rr – numbers are inserted always by 2 digits in range [01-16]

After reception of confirmation 🎵 is new value immediately active and you can test it.

Help: except inserting of direct values 01-16 you can add/ decrease amplification +/- by buttons on phone * = - and # = +

Limits of maximal and minimal loudness are acoustically signalling (3 tones as call termination signalling). When you dont press any digit within 5sec then setup value is saved and you hear confirmation tone 🎵.

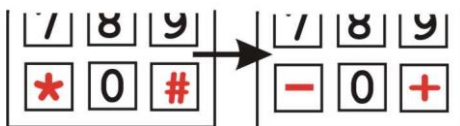

Note: After confirmation tone 🎵 is 5 sec open acoustic way with new acoustic parameters for short test.

CAUTION !! We dont recommend factory setting if necessary.

Principle of setting this parameters is on page: 25

Parametr	Value	Description	Default
74	c	Soft pass of switching (0/1)	0

In default this feature is off **c=0**. It is going about character of on line operation semiduplex switching. In case where character of depresser is too steep you can make it softer by **c=1**.

Parametr	Value	Description	Default
75	n	Depression of background sound (0/1)	0

In default it is off **n=0**. When communicator is installed in noisy environment (noisy streets, subway stations, parkings...) then by activation of this circuit **n=1** is setup level of noice as start level for microphone activation. Then the call connection is not one way opened. It relates with setup of parametres 71, 76, 77.

Parametr	Value	Description	Default
76	b	Level of microphone start 1-4 (4 is highest)	3

On the line is simultaneously signal from microphone and speaker. In handsfree circuit is a few functional filters to suppress acoustic shock. The basic one is circuit of semiduplex operation when incoming signal decrease microphone amplificatio as same as signal from microphone decrease incoming signal. The level of microphone start is setup by this parametr.. As lower value as higher microphone sensitivity is. In noisy environment we recommend higher value with combination of parametrs 71,75, 77.

Parametr	Value	Description	Default
77	s	Fast switching voice automatic 1-4 (4 is slowest)	2

At parametres 75, 76 is described principal of acoustic shock supression. Speed of circuit switching between incoming and outgoing sound is setup by parametr 77.

Switching time [ms]	S - dial
1	1
2	2
4	3
8	4

Parametr	Value	Description	Default
78	I	VoltAmper (VA) charakteristic of line connection (0/1)	1

Almost every country around the world has different telephone directives and this parametr allows decrease voltage at communicator line interface about 1V during OFF HOOK. Where directive requires decrease ment of line voltage **I=0** decrease voltage about 1V. In default **I=1**.

Parametr	Value	Description	Default
79	k	Compensation of wires losses depends on line current (0/1/2)	0

Communicator BLCL includes circuit which during long distance installations (100m and more from PBX) can compensate losses on wiring. In default the feature is off **k=0**. You can setup in two levels depending on line current of PBX (short circuit current I_0).

PBX current I_0	k - dial
Feature is off	0
20mA-50mA	1
45mA-75mA	2

Parametr	Value	Description	Default
70	uu	Transmission signalling level in [-dBm] (04-16)	04

uu – transmission signalling level to the line, range -4 to -16dBm. You insert desired level, uu=04 is -4dBm, uu=10 is -10dBm ...

Parametr	Value	Description	Default
7*	a	Time constant after pickup before initiati HF (0/1)	1

In default this feature is long time **a=1**. Long time is 500ms **a=1**, short time is 50ms **a=0**. If you pick up lines you not hear pickup tone, alternatively call begins dialing, so constant switch. Long time spans any flicker on the line after picking.

4.7 Option module parameters

This parameters are only for installed Talker module, but some are stored in the BraveLiftCallLine Basic board. Second possibilities is use Option module with FloorTalker connection

Parametr	Value	Description	Default
01	f	Connection Talker module or FloorTalker to the Option module (0/1/2/3/4/5/6/7)	0

- f** – 0 disable
 – 1 enable message H1 H1 is message to cabin (waiting)
 – 2 enable message H2 H2 is message to the line (place)
 – 3 enable message H1 + H2
 – 4 enable message H3 H3 is message end of call
 – 5 enable message H1 + H3
 – 6 enable message H2 + H3
 – 7 enable message H1 + H2 + H3

Parametr	Value	Description	Default
02	tt	Time delay befor dial emergency call (00-99)	0

- tt** – this time BraveLiftCallLine waiting on FILTER input, when FILTER is active before the expiry of tt, so the call will not go anywhere. Otherwise, the call occurs after time tt. (00 - disable, 01-99 is time in sec of delay of call)

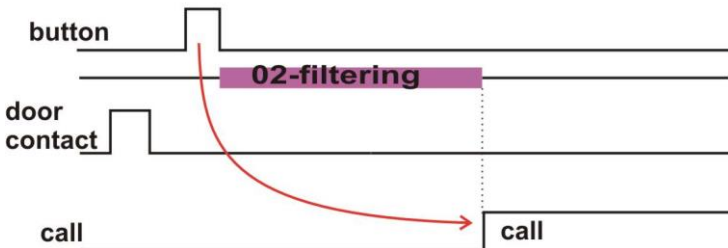
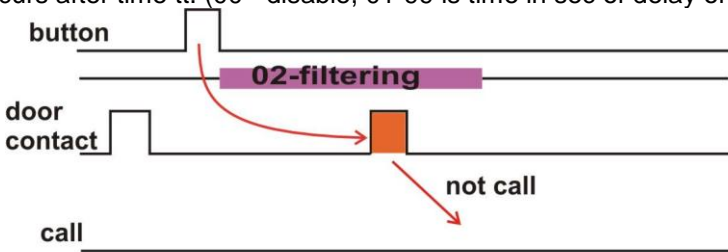

Time **tt** is recommended set to time of move cabin between lower to upper floor
!!! This function not working if is set parameter 34 = 2 or 3 or 4!!!

Parametr	Value	Description	Default
05	a	Enable test of acoustic path (0/1)	0

a – 0 disable

- 1 enable test of acoustic path. This test is automatic activate service call (par. 31) with interval (par. 59). If use confirm code (par. 07), so test of acoustic path is activate even if the service call is not allowed.

If the evaluated fault in the acoustic path, so before the service call is made cycle technical call with code "0".

Note: - if when using multiple microphones and speakers, so do not test all the paths but at least one functional.

- further acoustic test is dependent on environmental conditions (noise, shading, etc.), so they may not be meaningful and may occur technical call announcing the error and yet everything is fine (just for the test when someone is talking in the cabin, or the fan runs ...)

Note2: test provide up to 2 min periodic transmit all 16 codes of DTMF with change of level to the speaker and continuos receive from microphone any DTMF tone return. If yes, so acoustic path is OK, if no, so communicator make special technical call with DTMF code 0

Parametr	Value	Description	Default
06	t	Enable test of permanent activate buttons (0/1)	0

t – 0 disable

- 1 enable - the test of permanent activate button is checked if any call is ended. When conditions are fulfilled end of call and some button is still active so is invoked technical call with the code "7" and notify faulty button. When the evaluated permanently pressed button, so begins the cycle of technical calls after technical call communicator remains in a state of waiting for the deactivation button, ie after the repair button communicator automatically put into normal operation.

Parametr	Value	Description	Default
07	ssss	Confirm code, BraveLiftCallLine answer redial service telephone numbers and begin acoustic test (0-9999)	65

ssss – Confirm code - confirmed call, after receive this code BraveLiftCallLine hangup, and after timeout (parameter 32) make service call. [1-4digits]

This code is dialed to the call from telephone or Call centrum, this confirmation authorize call, LED yellow is light off and LED green is light on. You can use 1 - 4 digits long code, but before code you must dial common character **k** (parameter 4#)

Service call is make if is service call switch on (par. 31), acoustic test is make if is the test enabled (par. 05)

4.8 Presetting and erasing

Parameter	Value	Description	Default
8#	#	default	perform

This setting not influence parametres **1** and **2** (numbers saved in memory)

Parameter	Value	Description	Default
81		Erase all emergency phone numbers	1... only
82		Erase all another phone numbers	2... only
83		Default setting for parametres 3x only	3... only
84		Default setting for parametres 4x only	4... only
85		Default setting for parametres 5x only	5... only

86		Default setting for parametres 6x only	6... only
87		Default setting for parametres 7x only	7... only
80		Default setting for parametres 0x only	0... only

Parameter 81, 82 perform erasing of all numbers saved in memories of emergency, service and failure call.

Parametres 83 – 80 perform selected default for parametres 3.. – 0.. only

CAUTION !!! erasing is unreturnable !!! It is necessary programm again.

4.9 Ending of programming

Parameter	Value	Description	Default
9		E N D	

After **9** dial into programming tone the BraveLiftCallLine hangs up. When programming is via PREPOJ box from machine room it is not hangs but returns back to standard communication lift cabin-machine room.

4.10 Parameters overview

Parameter	Value	Description	Default
1	tp nn...	number nn in order t with confirmation p	-
21	p nn...	Number nn with confirmation p	-
22	p nn...	Number nn with confirmation p	-
31	a	Service calling is in status ON / OFF (0/1/2)	0
32	h	Period of waiting in service call [min] (0-9)	4
33	i	Polarity of buttons ALARM (0/1)	0
34	z	Polarity of FILTER input (0/1/2/3/4)	0
35	b	Number of repeat sequence emergency call (1-9)	3
36	c	Number of repeat technical call (1-9)	1
38	ee	Number of repeat service call (00-99)	00
39	i	Polarity of buttons ALARM2 (0/1)	0
41	v	Dial type v – tone / pulse (0/1)	0
42	z	Character to prolong the call (* / #)	*
43	bb	Command to hang up communicator by phone (00-99,*0-*9)	44
44	xxxx	Service password (0000-9999)	0000
45	p	Activation parallel mode of communicators (0/1)	0
46	n	Number of rings before pickup or number of communicator in parallel mode (1-5)	3
47	eeee	Confirm code, BraveLiftCallLine return serial number (0-9999)	66
49	oooo	Confirm code, BraveLiftCallLine answer redial emergency telephone numbers (0-9999)	68
40	ssss	Confirm code, BraveLiftCallLine return last two dialled telephone numbers (0-9999)	69
4*	kk	Constant for parallel mode - time for receive DTMF address of communicator (10-49)	25
4#	k	First character of confirm code (0-9/ * / #)	*
51	d	Maximal call duration (0-9,*,#)	4
52	w	Time of button ALARM2 pressing (holding) for emergency call activation (00-39)	02
53	z	Time of button ALARM pressing (holding) for emergency call activation (0/1)	05

54	r	Hanging up time during REDIAL (1-5)	1
55	s	Time before start dialling (1-5)	1
56	e	Time without ringing tone – call detection (1-0)	5
57	cc	Time waiting for confirmation [sec] (10-99)	25
58	hh	Number of rings before hang up (04-99)	12
59	g	Number of days after which is perform service call (1-59)	3
500	x	Middle frequency of tones detector (1-0)	3 (375-475Hz)
501	y	Number of busy tones (2-0)	4
502	z	Time of permanent tone duration (1-5)	3 (3s)
503	tt	Time of tone duration DTMF (tone) dial (04-16)	10 (100ms)
504	mm	Time of space duration between DTMF tones (04-16)	10 (100ms)
505	f	Time of Flash duration (1-6)	1 (100ms)
506	p	Time of pause duration / pause between numbers (1-0)	4 (800ms)
507	uu	Level of sending tone DTMF dial in [-dBm] (04-16)	10
508	p	preemphasis DTMF (0/1)	0
509	S	Listening – in DTMF – level (1-4)	2
61	z	Acoustic signalling (confirmation, error, empty memory, call termination...) (0/1)	1
62	v	Acoustic signalling off hook/on hook (0/1/2)	1
63	u	Acoustic signalling knocking to call (0/1)	0
64	i	Suppression of DTMF reception from microphone, mute for special call (0/1/2/3)	0
65	b	BabyCall – call without necessity programm phone number (0/1)	0
6*	t	delay start for PBx's with line testing (Siemens) (0/1)	0
71	gg	Reception loudness (SPK) 01-16 (16 is highest)	05
72	ff	Transmission loudness (MIC) 01-16 (16 is highest)	02
73	rr	Speaker loudness (TRH) 01-16 (16 is highest)	12
74	c	Soft pass of switching (0/1)	0
75	n	Depression of background sound (0/1)	0

76	b	Level of microphone start 1-4 (4 is highest)	3
77	s	Fast switching voice automatic 1-4 (4 is slowest)	2
78	l	VoltAmper (VA) charakteristic of line connection (0/1)	1
79	k	Compensation of wires losses depends on line current (0/1/2)	0
70	uu	Transmission signalling level in [-dBm] (04-16)	04
7*	a	Time constant after pickup before initiate HF (0/1)	1
01	f	Connection Talker to the Option module (0/1/2/3/4/5/6/7)	0
02	tt	Time delay befor dial emergency call (00-99)	0
05	a	Enable test of acoustic path (0/1)	0
06	t	Enable test of permanent activate buttons (0/1)	0
07	ssss	Confirm code, BraveLiftCallLine answer redial emergency telephone numbers (0-9999)	65
8#	#	Default	perform
82		Erase all another phone numbers	2... only
83		Default setting for parametres 3x only	3... only
84		Default setting for parametres 4x only	4... only
85		Default setting for parametres 5x only	5... only
86		Default setting for parametres 6x only	6... only
87		Default setting for parametres 7x only	7... only
80		Default setting for parametres 0x only	0... only
9		E N D	

5. Technical parametres

5.1 Electrical parametres

Parameter	Value	Conditions
Min line current	18mA	Line OFF HOOK
Min line voltage	18V	Line ON HOOK
Line voltage when is BraveLiftCallLine OFF HOOK (VA diagram)	< 8V < 12V	I = 20mA I = 60 mA
Maximum current in ON HOOK status	< 50uA	U = 60V
Impedance line ending	130R + 820R parall. 220n	Line OFF HOOK
Frequency range	300Hz – 3400 Hz	20 - 60mA
Ringing impedance	> 2Kohm	25 – 60 Hz
Sensitivity of ringing detection	min. 10 – 25 V	
Pulse dial	40 / 60 ms	
Tone dial level	-16 to -4 dBm	20 – 60 mA
Tone dial sensitivity	40 dB	20 – 60 mA
Tone detection sensitivity	30 dB	20 – 60 mA
Internal speaker impedance	8 ohms	
Speaker over / under cabin impedance	45 ohms	
Microphone (internal, external, over and under cabin)	Electret, 2.2 Kohms, 45-55 dB	
Operation temperaturte	- 20 to + 50 st	

Dimensions: 135 x 66 x 25 mm

Notes:

Produced by:

Distributed by:

Date of sales:



ALPHA
Tech

© JR 2011-18

version V4.9 XI/2018